

Air Sheathed Plug Heaters, Small Hot Air Generators

Be sure to refer to "Precautions for Use" in the Heaters for Air Heating Overview on P.1663.

Air Sheathed Plug Heater



RoHS 10

MAHP
(Air Sheathed, Three-phase 200V)

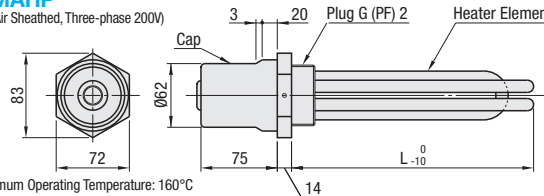

Maximum Operating Temperature: 160°C

M Material Element: SUS316L
Plug: SCS14
Cap: SCS13

A Accessory Gasket: Non Asbestos

Part Number Type	No.	L	W (Electric Power)	V (Voltage)	Electrical Power Density (W/cm ²)	Unit Price
	1	230	1000	200	2.5	
	2	400	2000			
	3	580	3000			
	4	760	4000			
	5	890	5000			

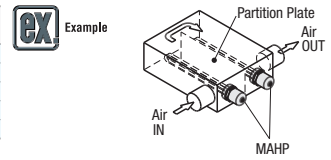

Ordering Example **Part Number**
MAHP3

The overall length has been shortened.

Small Hot Air Generators



RoHS 10

MAHZAS
(Standard)

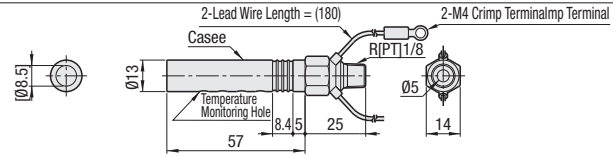

MAHZBS
(Point Tapered)

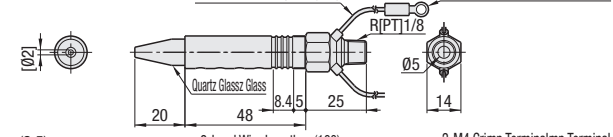

MAHZCS
(Flat Tip)

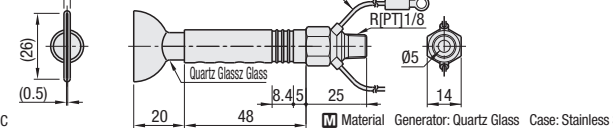

Maximum Operating Temperature: 800°C

M Material Generator: Quartz Glass Case: Stainless Steel

Part Number Type	No.	V (Voltage)	W (Electric Power)	Max. Flow (L/min)	Operating Gas Pressure kgf/cm ² (MPa)	Maximum Operating Temperature	Unit Price		
							MAHZAS	MAHZBS	MAHZCS
MAHZAS	1	100	350	60	2(0.2)	800°C			
MAHZBS	2	200	440						
MAHZCS	2	200	440						

As heat generation increase, temperature monitoring holes will turn red in order of 4 to 1. The load reaches the limit when the 4th to 2nd lights turn red and the 1st light remains black. Keep the color of the 4th hole unchanged when using.

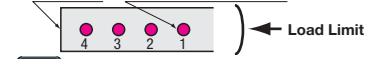

Ordering Example **Part Number**
MAHZAS1

Features
MISUMI's small hot air generators employ quartz glass which excels in heat-resistance on the body and ceramic processed special elements on the heat generator. Compact, safe, and clean hot air can be obtained.

- Usage**
- Spot Drying after Workpiece Cleaning
 - Welding of Resin Products
 - Soldering of Electronic Parts such as IC chips
 - Cap Seal Shrinkage (Shrink Packaging)
 - Cutting (heat cutting) of Resin Film etc.
 - Shrinkage of Pipe Wrapping Tubes

- Usage Procedure**
- Introduce compressed air before turning on small hot air generator.
 - Confirm the compressed air is flowing and apply a voltage to it.
 - Put the nozzle toward the object, and start heating.

* Temperature Controllers (P.1701) and Temperature Adjusters (P.1706) cannot be used.

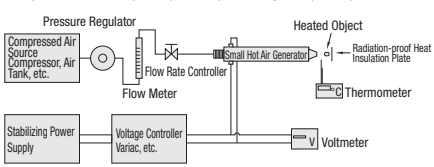

Calculation of Hot Air Temperature
Use the following formula to estimate hot air temperature.

$$\text{Hot Air Temperature } [^{\circ}\text{C}] \approx \frac{50 \times \text{Power Consumption [W]}}{\text{Flow Rate of Compressed Air [L/min]}}$$

Power consumption should be made smaller than W (electric power) of each type. The above formula is for reference. If hot air temperature is high while flow rate is small, heat efficiency may decrease. Hot air temperature must be set to lower than 800°C.

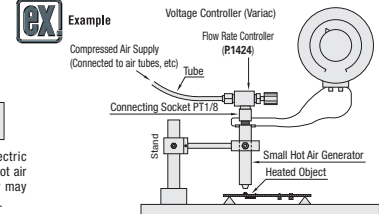
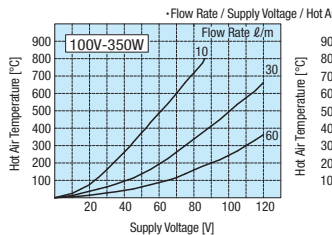

Applicable / Not Applicable Gases
The list below is for reference only and not a product guarantee.

Gas	Applicable or Not	Cautions and Others
Air, Oxygen	○	Avoid large amounts of oil mist or water.
Nitrogen, Argon	○	All inert gases are applicable, but they will decrease the life span of the product.
Hydrogen	△	Igniting occurs if the gas is exposed in the air at temperature 600°C or more.
Water Vapor	△	Letting the heat generator wet will cause breakage.
Town Gas, LPG	×	After thermal decomposition, carbon adheres to a heat generator.

- [IMPORTANT] Cautions**
- Check the air flow supply before applying a voltage. Never use without air flow.
 - After turning off the small hot air generator, please keep the compressed airflow for 3 min or more for the sake of safety. Then stop air flow supply when the temperature of the hot air becomes lower than 50°C.
 - Quartz glass is used on the body. Do not apply an impact.
 - The body and case get high temperature during the operation. Do not touch them. It will cause burn injury.
 - Voltage and electric power should be set lower than the rated values.
 - Do not exceed max. operating temperature (800°C).