

# Attachment Parts of Casters for Pipe Frames / How to Mount

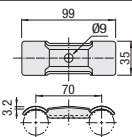

**RoHS10**

**Plates with Caster for Plastic Joints**

**JBS001** 

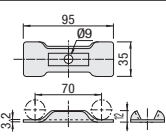
**JBS002** 

**Plate with Caster A for Metal Joints**

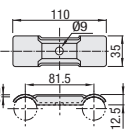
**JBS005** 

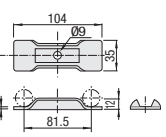
**JBS006** 

**M** Material SPCC  
**S** Surface Treatment Trivalent Chromate

Part Number	Mass (g)	Unit Price
JBS001	90	
JBS002	80	
JBS005	90	
JBS006	80	



**RoHS10**

**Caster Base A**

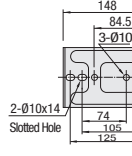
**JBS003** 

**Caster Base BR**

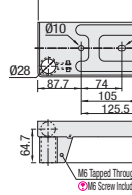
**JBS004R** 

**Caster Wrench 17/19**

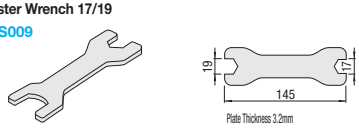
**JBS009** 

**Caster Base BL**

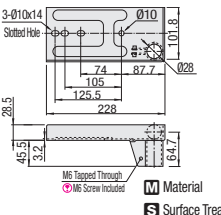
**JBS004L** 

**M** Material SPCC  
**S** Surface Treatment Trivalent Chromate

Part Number	Mass (g)	Unit Price
JBS003	380	
JBS004R	390	
JBS004L	890	
JBS009	110	

 **Ordering Example** **Part Number** **JBS003**

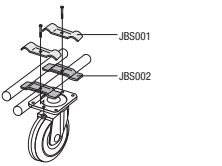
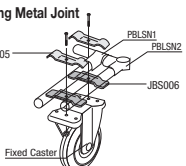
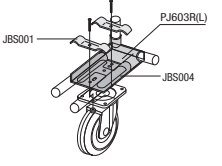
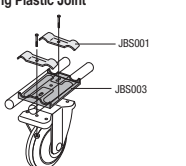

	App. Example of Swivel Type Caster (PHCH, PHCHS)	App. Example of Fixed Caster (PHCHK)
<b>Components</b>	 <p>Swivel Type Caster ..... 1 pc. Plate with Caster A (JBS001) ..... 2 pcs. Plate with Caster B (JBS002) ..... 2 pcs. Mounting Bolt, Spring Washer ..... 2 Sets</p>	 <p>Fixed Type Caster ..... 1 pc. Plate with Caster A (JBS005) for Metal Joint ..... 2 pcs. Plate with Caster B (JBS006) for Metal Joint ..... 2 pcs. Mounting Bolt, Spring Washer ..... 2 Sets</p>
<b>Components</b>	 <p>Swivel Type Caster ..... 1 pc. Plate with Caster A (JBS001) ..... 2 pcs. Caster Base B (JBS004) ..... 1 pc. Mounting Bolt, Spring Washer ..... 2 Sets</p>	 <p>Fixed Type Caster ..... 1 pc. Plate with Caster A (JBS001) ..... 2 pcs. Caster Base A (JBS003) ..... 1 pc. Mounting Bolt, Spring Washer ..... 2 Sets</p>

### Calculation of Caster Height

**How to Calculate**

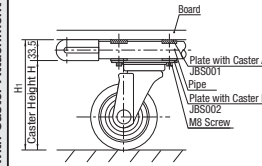

**Plate with Caster Attachment**

$H = 33.5\text{mm} + H$

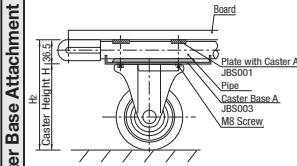

**Caster Base Attachment**

$H = 36.5\text{mm} + H$