



Magnetic Catches for Panels

HMGN (Pre-Assembly Insertion Nut)
HMGNA (Post-Assembly Fitting Nut)



With Sensor
HMGR (Pre-Assembly Insertion Nut)
HMGRA (Post-Assembly Fitting Nut)



Low Dust Generation
HMGCC (Pre-Assembly Insertion Nut)
HMGCCA (Post-Assembly Fitting Nut)



Low Dust Generation Magnetic Catches
The encapsulated structure of the magnet is effective in preventing rust and dust.
These magnetic catches are the best for the use in clean rooms.

Parts	Material	Surface Treatment
Magnetic Catch	N Magnet	Polyethylene
	HMGR-T	-
Door Side Plate	MGCC	Polyacetal
	N Plate	Zinc Plating Chromate
	S Plate	Trivalent Chromate
	C Plate	-
Mounting Plate	N Plate, S Plate	SPCC
	C Plate	Aluminum Alloy

RoHS 10

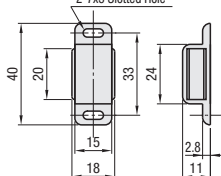
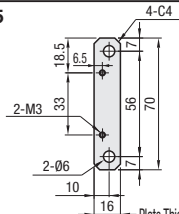
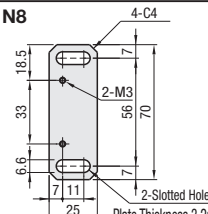
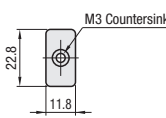
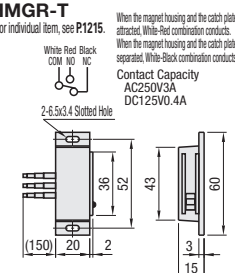
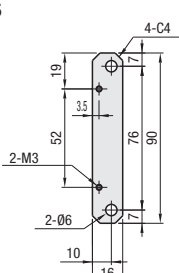
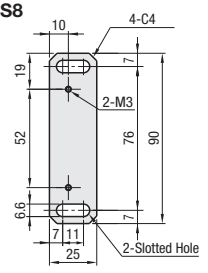
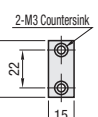
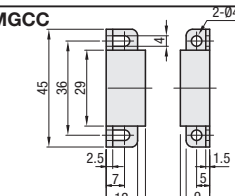
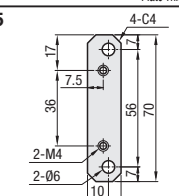
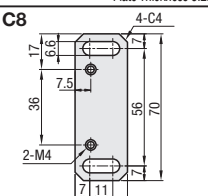
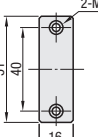
Type	Magnet Side	Mounting Plate for M5	Mounting Plate for M6, M8	Door Side Plate
Magnetic Catches	N Magnet 	N5 	N6, N8 	N Plate 
Magnetic Catches with Sensor	HMGR-T <small>* For individual item, see P1215.</small> <small>When the magnet housing and the catch plate are attracted, White-Red combination conducts. When the magnet housing and the catch plate are separated, White-Black combination conducts.</small> <small>Contact Capacity AC250V/3A DC125V/0.4A</small> 	S5 	S6, S8 	S Plate 
Low Dust Generation Magnet Catches	MGCC 	C5 	C6, C8 	C Plate 

Part Number	Type	No.	Magnet	Retaining Force N(kgf)	Mounting Plate	Component						Pre-Assembly Fitting Nut	Post-Assembly Fitting Nut				
						Magnet Side				Door Side				Unit Price	Volume Discount Rate	Unit Price	Volume Discount Rate
						For Magnet Mounting	For Extrusion Fitting			Door Side Plate	Mounting Screw						
HMGN (Pre-Assembly Fitting Nut) HMGNA (Post-Assembly Fitting Nut)	5 6 8		N Magnet	9.8 (1)	N5	For Magnet Mounting	For Extrusion Fitting			Door Side Plate	Mounting Screw	Acorn Nut	~ 4 pc(s)	5~100	1~4 pc(s)		
HMGR (Pre-Assembly Fitting Nut) HMGRA (Post-Assembly Fitting Nut)	5 6 8		HMGR-T	19 (2)	M3x6	Quantity	Screw	Quantity	Pre-Assembly Fitting Nut	Post-Assembly Fitting Nut	Quantity						
HMGCC (Pre-Assembly Fitting Nut) HMGCCA (Post-Assembly Fitting Nut)	5 6 8		MGCC1 (Black) MGCC2 (Gray) MGCC3 (White)	1.0 1.4 2.0	M4x4	Quantity	SCB5-8 SCB6-10 SCB6-15	Quantity	HNTT5-5 HNTT6-6 HNTT8-6	Quantity	HNTA5-5 HNTA6-6 HNTA8-6	Quantity					

Ordering Example

Part Number - Magnet
HMGN6 - 1

EX Example

