

Post-Assembly Insertion Easy Brackets

For 8 Series (Slot Width 10mm) Aluminum Extrusions

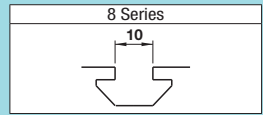

Features: 2 aluminum extrusions can be easily connected with only 1 tightening screw. Brackets can be mounted on the extrusion slots after assembly.

Post-Assembly Insertion Easy Brackets

Components	Material	Surface Treatment
① Joint Plate	SPPC	
② Joint Brackets	S45C Equivalent	Trivalent Chromate
③ Hex Socket Head Cap Screw	SCM435	



RoHS10

HABL8 ① Joint Plate

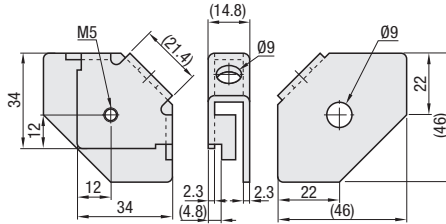

② Joint Brackets

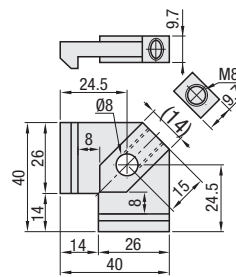

③ Hex Socket Head Cap Screw

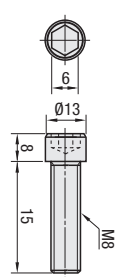

⚠ Overtightening may cause deformation of joint plates. (Reference Tightening Torque 15N·m)

Part Number Type	Mass (g)	Included Screw		Allowable Load (N)	Unit Price 1~99 pc(s).	Volume Discount Rate 100~200
		Screw	Quantity			
HABL8	120	Hex Socket Head Cap Screw M8x15	1	800		



Ordering Example

Part Number
HABL8

Connection Method

Step Front View Side View Sketch Drawing

Sketch Drawing



Example

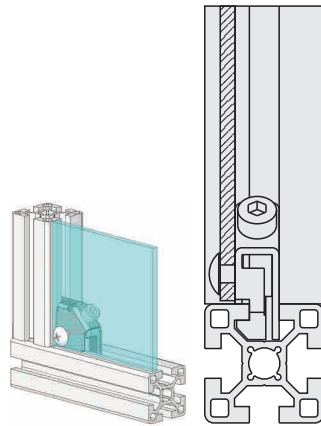

Holes are tapped on a bracket for cover mounting.

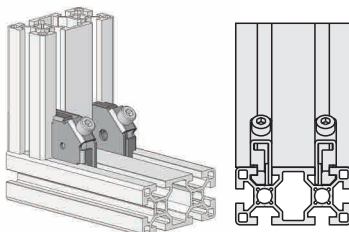

For aluminum extrusions with 2 slots, brackets can be mounted on both sides.

