

# Extruded Brackets - For 1 Slot

## For 6 Series (Slot Width 8mm) Aluminum Extrusions

■ **Features:** Numbers of screws are the same as HBLTS6. Extrusions can be connected more securely.

■ **Ultra Thick Brackets**

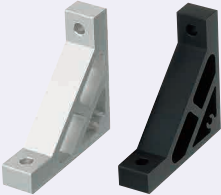

**HBLUS6**  
**HBLUSB6**  
(Black Anodize)

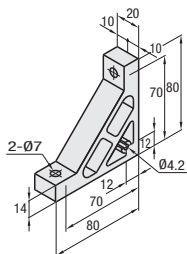

Type	Material	Surface Treatment
HBLUS6	AGN01SS-T5	Anodize
HBLUSB6		Black Anodize

Part Number Type	Mass (g)	Applicable Screw, T Nut				Allowable Load (N)	Unit Price 1~99 pc(s).	Volume Discount Rate 100~200
		Screw	Quantity	T Nut	Quantity			
<b>HBLUS6</b> <b>HBLUSB6*</b> (Black Anodize)	101	CBM6-20	2	HNTT6-6	2	1176		

\* For repairing black anodizing, refer to P846.

■ **Features:** Hole positions are offset. Can be combined with plates of 3mm and 5mm thickness when using taps for mounting covers.

■ **Eccentric Brackets**

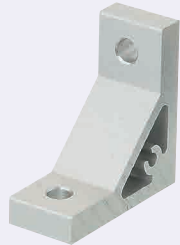

**HBLTH6**

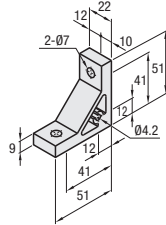

**M**Material: AGN01SS-T5  
**S**Surface Treatment: Anodize

**EX** Example

They can be combined with cover plates of thickness 3mm and 5mm.

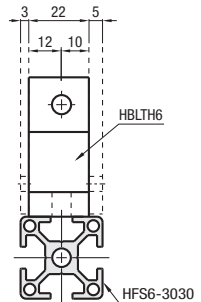

Part Number Type	Mass (g)	Applicable Screw, T Nut				Allowable Load (N)	Unit Price 1~99 pc(s).	Volume Discount Rate 100~200
		Screw	Quantity	T Nut	Quantity			
<b>HBLTH6</b>	44	CBM6-15	2	HNTT6-6	2	1176		

■ **Features:** Extruded Brackets with Unequal Sides. Effective when strength is required in narrow clearances between extrusions.

■ **Scalene Brackets**



**HBLTF6**

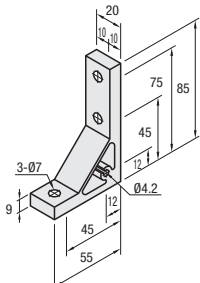

**M**Material: AGN01SS-T5  
**S**Surface Treatment: Anodize

Part Number Type	Mass (g)	Applicable Screw, T Nut				Allowable Load (N)	Unit Price 1~99 pc(s).	Volume Discount Rate 100~200
		Screw	Quantity	T Nut	Quantity			
<b>HBLTF6</b>	62	CBM6-15	3	HNTT6-6	3	1470		

**EX** Example

