

■ **Features:** Three-sided extrusion end caps for protecting 3 corners. Alterations not necessary.

■ **Three-Sided Caps for Corners**



⚠ The pin shape and numbers of extrusion caps may be changed to prevent caps from easily falling off.

RoHS10

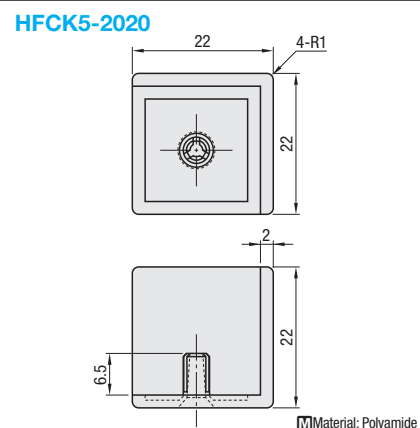

Ordering Example **Part Number** - **Color**
HFCCK5-2020 - **B**

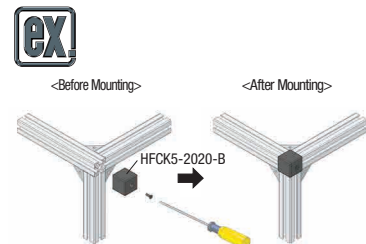

⚠ Tapping on extrusion is not required.

Part Number	Color	Accessory	Applicable Extrusion	Unit Price 1 ~ 14 pc(s).	Volume Discount Rate 15-19	Volume Discount Rate 20-200
HFCCK5-2020	B (Black)	HFBMB3-12	5-2020			

■ **Features:** Extrusion End Caps Screw Mounting Type. Requires no alteration and excels in safety.

■ **Screw Mounted**



⚠ The pin shape and numbers of extrusion caps may be changed to prevent caps from easily falling off.

RoHS10

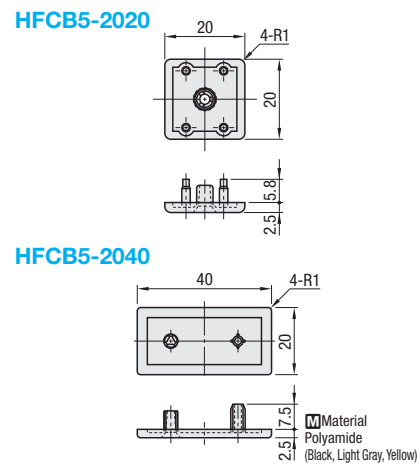

Ordering Example **Part Number** - **Color**
HFCB5-2020 - **B**

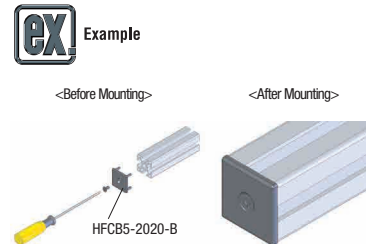

⚠ Tapping on extrusion is not required.

Part Number Type	No.	Color	Unit Price	Volume Discount Rate	Applicable
			1 ~ 14 pc(s).	15-19	20-500
HFCB5	2020	B (Black) S (Light Gray) Y (Yellow)			5-2020
	2040	⚠ Yellow Type is available only for 2020.			5-2040

⚠ Flat Head Screw is included. (Black: HFBMB3-12, Light Gray, Yellow: SHFBS3-12)

■ **Features:** End plates for HFSR5-404020. Alterations are required on extrusions.

■ **End Plates** **RoHS10**



Material: SUS304

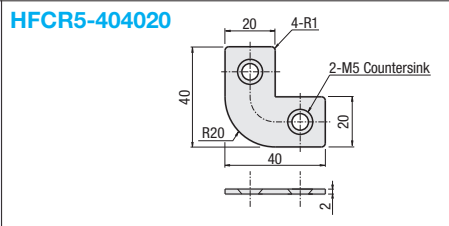

■ **End Plates Mounting for HFSR5-404020**

Alterations	Hole Machining for End Plate Mounting			
	Code	LTS	RTS	TSW
Spec.	The diagram below shows the basic extrusion position. LTS: Machined on the Left End RTS: Machined on the Right End TSW: Machined on Both Ends Ex. LTS			
Applicable Extrusion	HFSR5-404020	Applicable Screw	SHFBS5-6	

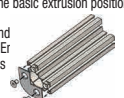

Part Number Type	Applicable Screw	Unit Price 1 ~ 14 pc(s).	Volume Discount Rate 15-19	Volume Discount Rate 20-200	Applicable Extrusion
HFCR5-404020	SHFBS5-6				HFSR5-404020

⚠ For HFCR5-404020, alterations on the extrusion end section and applicable screws are required for mounting. (Screws are not included.)

Ordering Example **Part Number**
HFCR5-404020