

Strut Clamps

Vertical Taps With Clamp Lever / Parallel Taps With Clamp Lever

■ **Features:** Convenient for frequent setup changes. Vertically adjustable with a clamp lever without tools.

■ Vertical/Parallel Taps With Clamp Lever



RoHS 10

Type			Material	Surface Treatment
Vertical Taps	Parallel Taps			
Thin	Thin	Standard		
KMKU	KQKU	KQK	SS400	Black Oxide
MMKU	MQKU	MQK		Electroless Nickel Plating
AMKU	AQKU	AQK		Black Anodize
SMKU	SQKU	SQK	SUS304	-

■ Clamp Lever (Refer to P.2-1139)

DH7	Thin		Standard
	Thin	Standard	
10	CLDM5-16-M	CLDM6-16-M	
12	CLDM5-20-M	CLDM6-16-M	
15	CLDM5-20-M	CLDM8-20-M	
20	CLDM6-25-M	CLDM8-25-M	
25	CLDM6-32-M	CLDM10-32-M	
30	CLDM6-32-M	CLDM10-40-M	
35	CLDM8-40-M	CLDM12-40-M	

6.3 / (6.3 / 1.6)

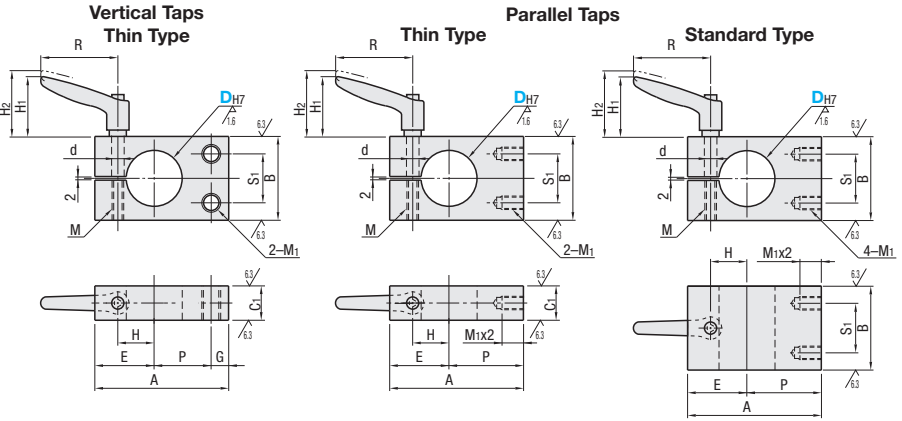

■ Vertical Taps Thin Type

Part Number	Type	DH7	P	A	B	C ₁	E	G	H	S ₁	M ₁	M	d	Clamp Lever			Unit Price												
														H ₁	H ₂	R	KMKU	MMKU	AMKU	SMKU									
10	KMKU MMKU AMKU SMKU	+0.015 0	11	31	16	9	15	5	9	8	M4	M5	5.5	35	38.5	45													
12		+0.018 0	13	34			16		10								8												
15		0	17	45	22	12	20	8	12	12	M5																		
20		+0.021 0	20	52	28	16	22	10	15	16	M6						M6	6.6											
25		0	23	58	32	25	18		20	20																			
30		+0.025 0	27	66	38	19	29		21	25	M8											M8	9	45.5	49	63			
35		0	30	72	45	22	32	24	28																				

⊕ For the available sizes, refer to the price list. ⊕ DH7 tolerance is before the slit machining.
⊕ For mating, g6, f8 shaft tolerances are recommended.

■ Parallel Taps Thin Type

Part Number	Type	DH7	P	A	B	C ₁	E	H	S ₁	M ₁	M	d	Clamp Lever			Unit Price													
													H ₁	H ₂	R	KQKU	MQKU	AQKU	SQKU										
10	KQKU MQKU AQKU SQKU	+0.015 0	16	31	16	9	15	9	8	M4	M5	5.5	35	38.5	45														
12		+0.018 0	18	34			16									10	8												
15		0	25	45	22	12	20	12	12	M5																			
20		+0.021 0	30	52	28	16	22	15	16	M6						M6	6.6												
25		0	33	58	32	19	25	18	20																				
30		+0.025 0	37	66	38	19	29	21	25	M8											M8	9	45.5	49	63				
35		0	40	72	45	22	32	24	28																				

⊕ For the available sizes, refer to the price list. ⊕ DH7 tolerance is before the slit machining.
⊕ For mating, g6, f8 shaft tolerances are recommended.

■ Parallel Taps Standard Type

Part Number	Type	DH7	P	A	B	E	H	S ₁	M ₁	M	d	Clamp Lever			Unit Price													
												H ₁	H ₂	R	KQK	MQK	AQK	SQK										
10	KQK MQK AQK SQK	+0.015 0	16	32	16	10	17	11	8	M4	M6	6.6	35	38.5	45													
12		+0.018 0	18	35												17	11	8										
15		0	25	47	22	22	14	12	M5																			
20		+0.021 0	30	54	28	24	16	16	M6	M8						9	45.5	49	63									
25		0	33	62	32	29	20	20																				
30		+0.025 0	37	68	40	31	22	25	M8											M10	11	55	59	78				
35		0	40	77	45	37	26	28																				

⊕ For the available sizes, refer to the price list. ⊕ DH7 tolerance is before the slit machining.
⊕ For mating, g6, f8 shaft tolerances are recommended.

