

Magnetic Bases / Shaft Mounts / Dial Mounts

■ Features: Compact but achieves strong attraction forces by using the Neodymium Iron Boron Magnet. 📏 For Arm Sets, **P2034**

■ Magnetic Bases



RoHS10

MGNBS (No.20)

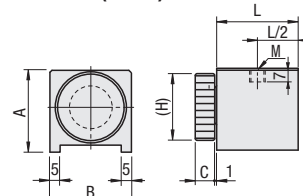

(No.40, 80, 100)

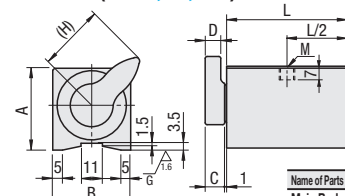

Name of Parts	M Material	S Surface Treatment
Main Body	SS400	Paint Finish
Magnet	Neodymium Magnet	-
Knob	ABS	-

⚠ Due to the wrinkle paint finish, B Dimension tolerance will be $+1.5$
 ⚠ Do not attach magnetic objects.

Part Number Type	No.	Attraction Force N	A	B	L	(H)	C	D	M (Coarse)	Weight (g)	Unit Price 1 ~ 9 pc(s).	Volume Discount Rate 10 ~ 20 pcs.
MGNBS	20	200	30	30	30	25	9	-	M6	200		
	40	400	40	40	42	34	10	8	M8	400		
	80	800	42	40	62					700		
	100	1000	42	40	73					800		

⚠ For orders larger than indicated quantity, please check with WOS.

■ Shaft Mounts - Built-in Spring



KSHL D12, 16, 20

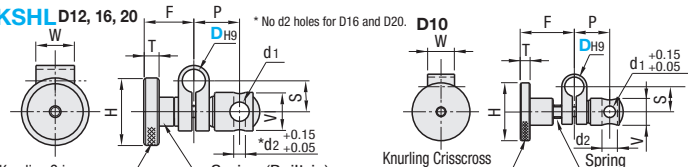

* No d2 holes for D16 and D20. **D10**

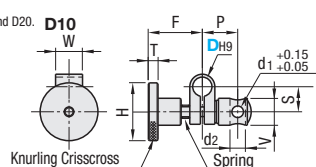

M Material	S Surface Treatment
S45C	Black Oxide

Part Number Type	No.	DH9	d1 Diameter Tolerance	d2	P	F	H	S	V	T	W	Unit Price 1 ~ 9 pc(s).	Volume Discount Rate 10 ~ 20 pcs.
KSHL	10	$+0.036$	8 $+0.15$ $+0.05$	6	18.4	28	30	13	14	5	14		
	12	$+0.043$	10 $+0.036$ 0	-	24	26	35	16	20	8	20		
	16	$+0.043$	12 $+0.043$ 0	-	27.5	32	40	22	28	8	28		
	20	$+0.052$	12 $+0.043$ 0	-	38.5	40	50	28	28	10	30		

⚠ For orders larger than indicated quantity, please check with WOS.

■ Shaft Mounts



RoHS10

MGNBSH

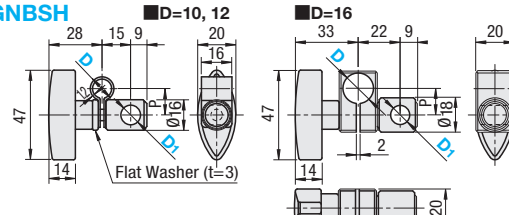

Name of Parts	M Material	S Surface Treatment
D (D=10, 12)	SK5	Black Oxide
D (D=16), D1	SUM22	Black Oxide
Knob	ABS	-

Part Number Type	D	D1	P	Weight (g)	Unit Price 1 ~ 9 pc(s).	Volume Discount Rate 10 ~ 20 pcs.
MGNBSH	10	8	14	50		
		10				
	12	8	16.5	50		
		10				
		12				
16	12	14	100			

■ Dial Mounts



RoHS10

MGNBSD

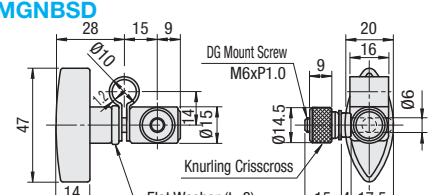

Name of Parts	M Material	S Surface Treatment
Ø10	SK5	Black Oxide
Main Body and Mounting Screw	SUM22	Black Oxide
Knob	ABS	-

Part Number	Weight (g)	Unit Price 1 ~ 9 pc(s).	Volume Discount Rate 10 ~ 20 pcs.
MGNBSD	70		

⚠ For orders larger than indicated quantity, please check with WOS.

ex Example **■ Dial Mount App. Example**

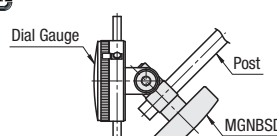

Ordering Example

Part Number - **D1**

MGNBS80

KSHL12

MGNBSH12 - **8**

MGNBSD