

# [Motorized] Z-Axis, Linear Ball Slide

**Features:** Z-Axis Stage with integrated Linear Ball Guides, with High Precision and rigidity.

## Z-Axis Motorized Stage

The photo is for the Cover Position R Type.



- M** Material: SUS440C Equivalent
- S** Surface Treatment: Electroless Nickel Plating
- A** Accessory: ZMSG413/513: SCB3-10, 4 pcs.  
ZMSG615: SCB4-12, 4 pcs.  
ZMSG715: SCB3-12, 4 pcs.

For Controllers, Handset Terminals, see P. 1-2014-1-P. 1-2014-2

RoHS10

### ZMSG413

### ZMSG513

The drawing is for the L (left) Cover Position Type.

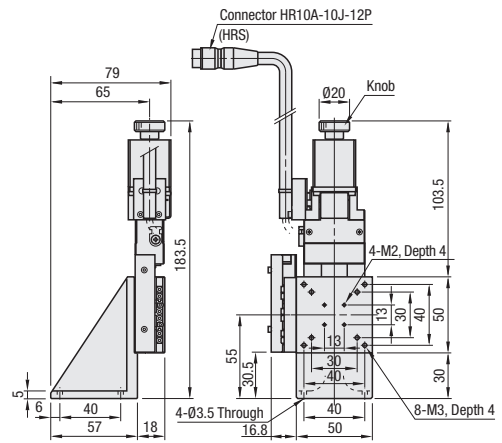
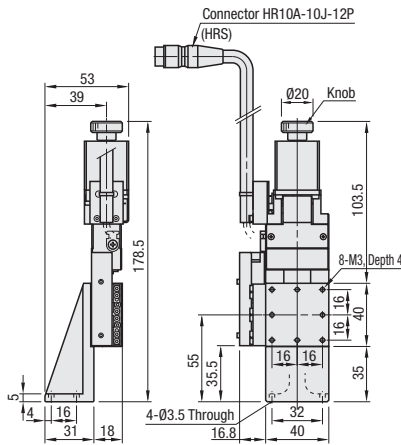

### ZMSG615

### ZMSG715

