

Points on Similar Product Comparison | Travel Accuracy Straightness 10µm

Similar Product Pages P.1966

Features: Incorporated Linear Ball Slide Guide mechanism achieves high load capacity.

**Z-Axis**

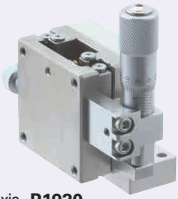

X-Axis **P.1920**  
Y-Axis **P.1942**

RoHS 10

**ZLBS40**  
(Standard)

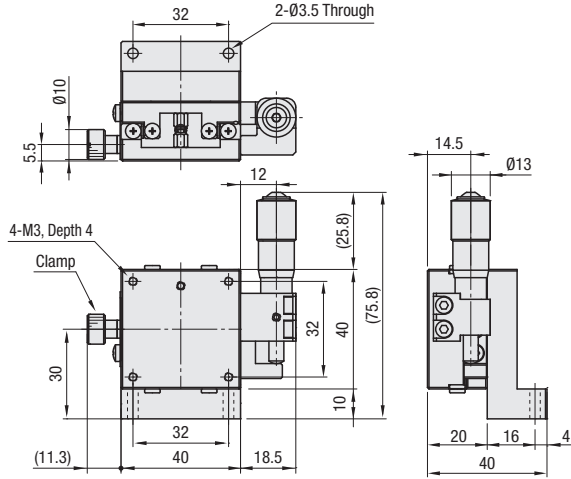

**ZLBS□-CR**  
(Reversed)

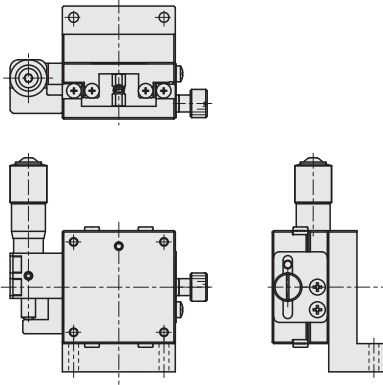

**ZLBS60**  
(Standard)

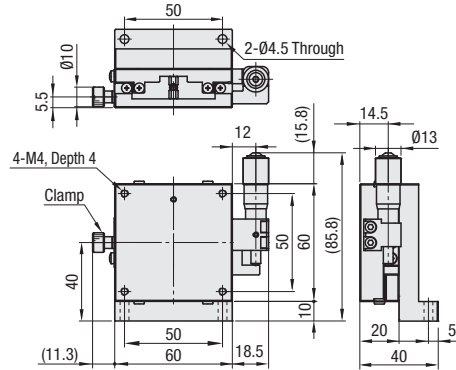

**M** Material: (Main Body) SUS440C, (Bracket) Steel (SS400)  
**S** Surface Treatment: (Main Body) Electroless Nickel Plating, (Bracket) Electroless Nickel Plating

High Precision Stage Existing Product: ZSG (P.1966)

Part Number			Stage Surface (mm)	Travel Distance (mm)	Load Capacity (N)	Minimum Graduation (µm)	Travel Accuracy			Moment Rigidity ("/N-cm)			Weight (kg)	Included Screw (SUS Hex Socket Low Head Cap Screw)	Unit Price
Type	No.	Micrometer Head Position					Straightness	Pitching	Yawing	Pitching	Yawing	Rolling			
ZLBS	40	No Symbol (Standard)	40x40	±6.5	19.6	10	10µm	30"	25"	0.38	0.35	0.21	0.43	M3-16, 2 pcs.	
	60	CR (Right/Left Reversed)	60x60					35"	30"	0.1	0.08	0.05	0.83	M4-16, 2 pcs.	



Ordering Example

Part Number  
**ZLBS40**