

Holders for Locating Pins

Standard, Compact Flange

■ **Features:** Use in combination with Locating Pins Set Screw Type (P.1624, etc.) and Internal Thread Type (P.1577, etc.) enables locating at higher position.

■ **Standard**



RoHS 10

Material	Surface Treatment	Set Screw Mounted	Screw Mounted
S45C	Black Oxide	M-LPHT	M-LPHB

• Set Screw Mounted

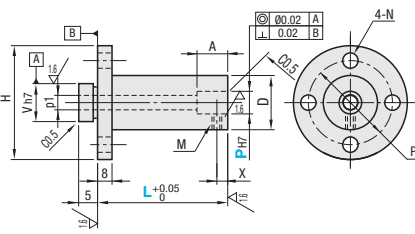

• Screw Mounted

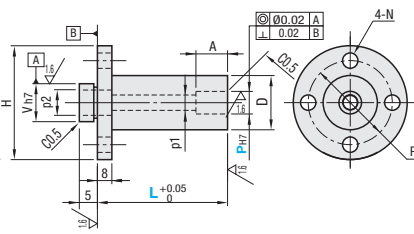

$\nabla \left(\frac{1.6}{\nabla} \right)$

■ **Set Screw Mounted and Screw Mounted**

Part Number Type	P	L 0.1mm Increment	D	V	p1	p2	*A	M (Coarse)	X	N	P.C.D.	H	Unit Price					
													Min. L - 100.0	L100.1-150.0	L150.1-200.0			
(Set Screw Mounted) M-LPHT	6	20.0~100.0	12	12	3.5	6.5	10	M3	4.5	4.5	30	39						
	8	25.0~100.0	15				15		5									
	10	30.0~100.0	17	15	5.5	9.5	16	M4	7									
(Screw Mounted) M-LPHB	12		18			20					5.5		34	44				
	13		20			22					6.5		43	53				
	16	40.0~150.0	27	20	9	14	24											
20	45.0~200.0	32				32				6.5	49	63						

* When using with Locating Pins, L dimension (under-head length) ≤ A dimension (shown above).

■ **Compact Flange**



RoHS 10

Material	Surface Treatment	Set Screw Mounted	Screw Mounted
S45C	Black Oxide	LPHT	LPHB

• Set Screw Mounted

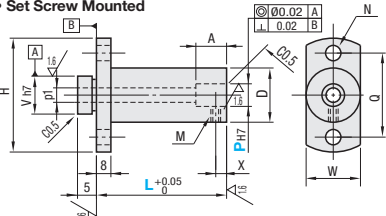

• Screw Mounted

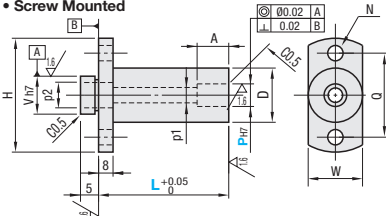

* When P dimension 6~12 with L>100, concentricity is 0.05 and L dimension tolerance is $^{+0.1}$.

 $\nabla \left(\frac{1.6}{\nabla} \right)$

■ **Set Screw Mounted and Screw Mounted**

Part Number Type	P	L 0.1mm Increment	D	V	*p1	p2	*A	M (Coarse)	X	N	Q	H	W	Unit Price				
														Min. L - 100.0	L100.1-150.0	L150.1-200.0		
(Set Screw Mounted) LPHT	6	20.0~150.0	12	12	3.5	6.5	10	M3	4.5	4.5	30	39	13					
	8	25.0~150.0	15				15		5							16		
	10	30.0~150.0	17	15	5.5	9.5	16	M4	7							18		
(Screw Mounted) LPHB	12		18			20					5.5		34	44	19			
	13		20			22					6.5		43	53	21			
	16	40.0~150.0	27	20	9	14	24								28			
20	45.0~200.0	32				32				6.5	49	63	33					

* When using with Locating Pins, L dimension (under-head length) ≤ A dimension (shown above). * For P=6, p1 of L>100 is 5; for P=8, 10 and 12, p1 of L>100 is 7.

Ordering Example

Part Number	-	L
LPHT8	-	L30.0

Example

