

# Small Diameter Height Adjusting Pins / Small Diameter Plunging Locating Pins

**Features:** Small Diameter Height Adjusting Pins achievable accuracy in height tolerance is 1/100. Suitable for locating of circuit board in vertical direction.

**Small Diameter Height Adjusting Pins**



RoHS 10

Part Number		Material
Press Fit	Threaded	
SFHH	SFNN	SUS304

$6.3 / (1.6 / 0.4 / 0.1)$

**Press Fit**

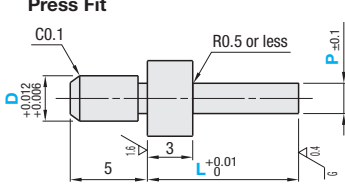

**Threaded**

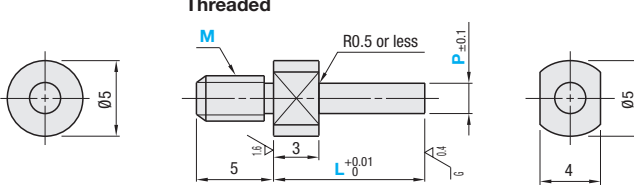

**Press Fit**

Part Number	L	P	Unit Price
TYPE	0.01mm Increment	0.5mm Increment	
SFHH	3	5.00-15.00	1.0-3.0

**Threaded**

Part Number	L	P	Unit Price
TYPE	0.01mm Increment	0.5mm Increment	
SFNN	3	5.00-15.00	1.0-3.0

**Ordering Example**

Part Number	-	L	-	P	
SFHH3	-	L9.98	-	P2.0	(Press Fit)
SFNN3	-	L6.50	-	P2.5	(Threaded)

**Example**

Suitable for supporting a circuit board with components installed on both sides.

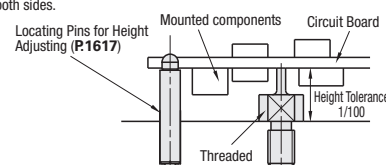

**Features:** Small Dia. Pin Units with spring-retained stroking pins.

**Small Diameter Plunging Locating Pins**



RoHS 10

Part Number	① Main Body	② Pin	③ Plug	④ Spring	⑤ Nut
	Material	Material	Material	Material	Material
DSDP	SUS304	SUS304 (Sliding Section: Fluorine Coating)	SUS304 Equivalent	SUS304-WPB	SUS304 Equivalent

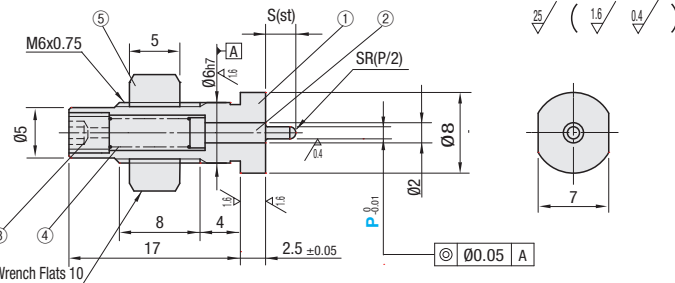

Part Number	P	S	Load (N)		Unit Price
			min.	max.	
DSDP	0.01mm Increment				
	1.00-1.50	3.0	0.2	0.48	
	1.51-1.99	4.5	0.2	0.64	

**Ordering Example**

Part Number	-	P
DSDP	-	P1.70

**Example**

The pin will sink when load is applied on spring-loaded locating pin.

