

Cam Followers

Hex Socket on Head / Thread (Crowned Type with Grease Fitting)

■ **Features:** Hex socket and grease fitting are mounted on both the head and thread part. You can secure it from either head or thread side using a hex wrench. Greasing is possible from both directions.

■ **Crowned**



RoHS 10

Application	Type		Material	Accessory
	With Seal	No Seal		
General	CFUH	CUH	SUJ2	1 Hex Nut (S45C Carbon Steel, Black Oxide)
Low Dust Generation	CFUSH	CUSH	SUS440C Equivalent	Hex Nut 1 pc. (SUS304)
Heavy Load	CFUGH	-	SUJ2	1 Hex Nut (S45C Carbon Steel, Black Oxide)

■ **With Seal**

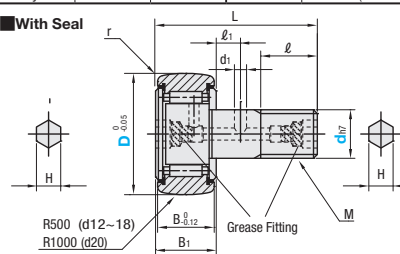

R500 (d12-18)
R1000 (d20)

■ **No Seal**

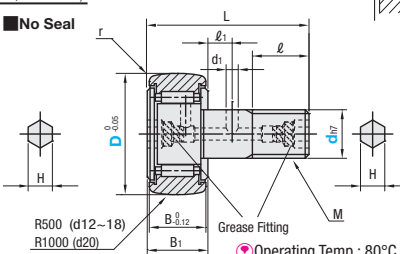

R500 (d12-18)
R1000 (d20)

Ⓜ Operating Temp.: 80°C or lower

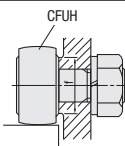

Part Number		D (Selectable)	MxPitch	B	B ₁	L	d ₁	ℓ	ℓ ₁	r	f (Min.)	H	Mass (g)	Max. Tightening Torque (N • cm)	Unit Price					
Type	dh7 Tolerance														CFUH	CFUSH	CFUCH	CFUGH	CUH	CUSH
(With Seal) CFUH CFUSH CFUCH CFUGH	12	0 -0.018	30	12x1.5	14	15	40	14	6	20	6	105(107)	29.4							
			32																	
	16	0 -0.018	35	16x1.5	18	19.5	52	18	8	24	6	205(207)	70.6							
			40																	
	18	0 -0.018	47	18x1.5	20	21.5	58	20	1.5	26	8	295(300)	98							
			52																	
	20	0 -0.021	62	20x1.5	24	25.5	66	22	9	36	8	450(455)	137							
			72																	
	(No Seal) CUH CUSH	24	0 -0.021	80	24x1.5	29	30.5	80	25	11	40	8	915(925)	245						
				85																
30	0 -0.021	90	30x1.5	35	37	100	32	15	2	46	8	1880(1890)	480							
		90																		

Ⓜ For the performance of Cam Followers, see Table 1 on P.1043.

Ordering Example Part Number - D
CFUH20 - 52

ⓘ **Part Number Substitution Table for Cam Follower Standard Changes (D30-40,52 only)**

Type	Old Part Number (D30-40,52)			New Part Number
	Old Standard	Old Hex Socket Type	Old Hex Socket on Thread	
Cam Followers	CFUR	CFUA	CFUB	CFUH
	CFURS	CFUAS	-	CFUSH
	CFURC	CFUAC	-	CFUCH
	-	CFUAG	-	CFUGH
	CFU	CUA	-	CUH
	CFUS	CUAS	-	CUSH
	CFFR	CFFA	CFFB	CFFH
	CFFRS	CFFAS	-	CFFSH
	CFFRC	CFFAC	-	CFFCH
	-	CFFAG	-	CFFGH
	CFR	CFA	-	CFAH
	CFRS	CFAS	-	CFASH