

# Oil Free Slide Plates

## Copper Alloy

■ **Features:** With thread locking treatment screw to prevent falling-off due to looseness (UTW type only) ◉ For material characteristic values, refer to P.380. ◉ Initial greasing is recommended for effective use.

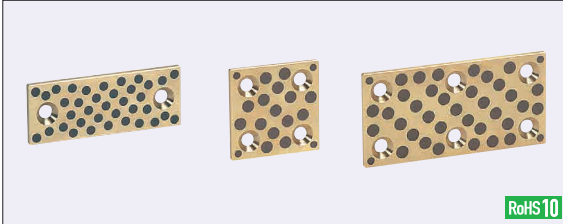

RoHS10

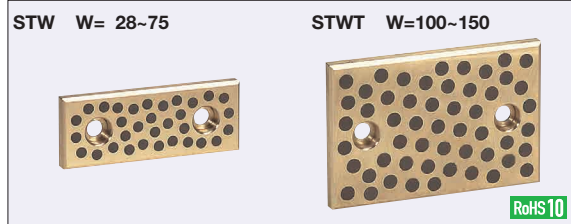
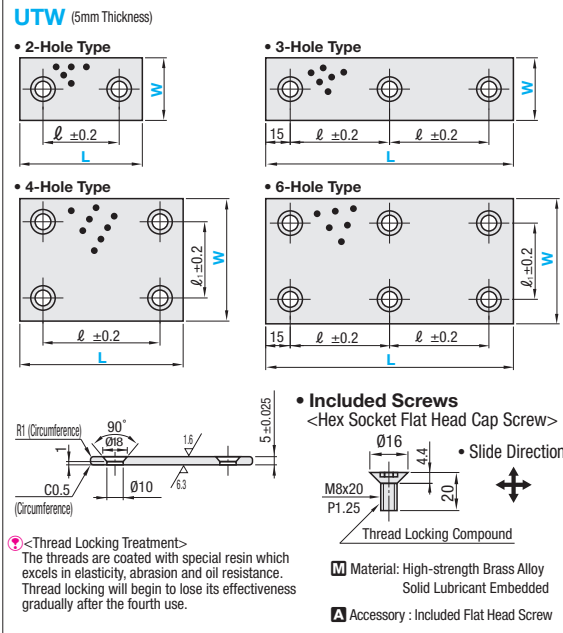

RoHS10

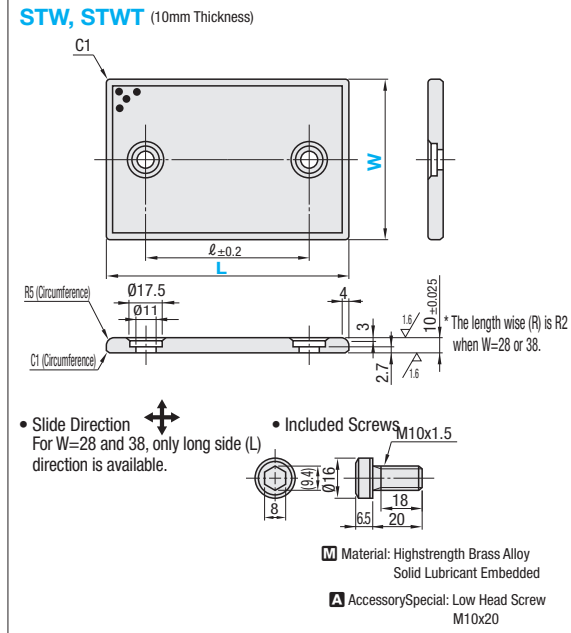

Part Number	W	L	Mounting Hole Type	ℓ	ℓ <sub>1</sub>	Unit Price	
UTW	28	50	2 Holes	20	-		
		75		45			
		100		70			
	38	50	2 Holes	20			
		75		45			
		100		70			
	48	50	2 Holes	20			
		75		45			
		100		70			
	75	75	2 Holes	45			45
		100		70			
		125		95			
100	150	3 Holes	60	70			
	75	4 Holes	45				
	100		70				
125	75		4 Holes	45			
	100	70					
	125	95					
150	150	6 Holes	60				
	100	4 Holes	70				
	125		95				
150	6 Holes		60				

Part Number	W	L	ℓ	Unit Price
STW	28	75	45	
		100	50	
		125	75	
		150	100	
	38	75	45	
		100	50	
		125	75	
		150	100	
		75	45	
		100	50	
	48	125	75	
		150	100	
		75	45	
		100	50	
		125	75	
		150	100	
	75	200	150	
		75	25	
100		50		
125		75		
150		100		
200		150		
STWT	100	100	50	
		125	75	
		150	100	
		200	150	
	125	250	200	
		150	100	
		200	150	
		250	200	
	150	150	100	
		200	150	
		250	200	
		200	150	



Ordering Example  
 Part Number    W    -    L  
 UTW            75    -    100