

SJT TYPE



There are some non-conforming products.



Swivel



Screw-in type



Double Bearing



SJT-125W, M20 x 40

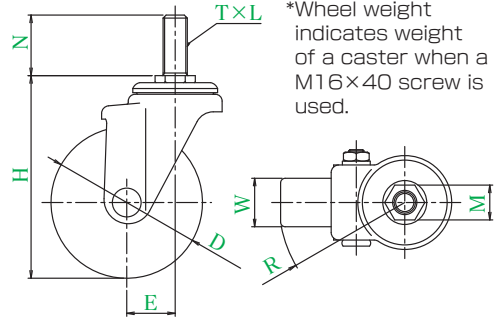

*Wheel weight indicates weight of a caster when a M16 x 40 screw is used.

● Description of product number
Please specify screw type and length.

SJT - 125 W , M20 x 40

Bracket type	Wheel diameter	Wheel type	Screw	Length
--------------	----------------	------------	-------	--------

Bracket = Trivalent unichrome coating

Product number	Wheels	Wheel diameter	Wheel width	Mounting height	Screw	Pitch	Length	Opposite side	Eccentricity	Turning radius	Allowance load	Wheel weight	
		D(mm)	W(mm)	H(mm)	T	L	N(mm)	M(mm)	E(mm)	R(mm)	daN(kgf)	(g)	
SJT-100	W	100	32	134	M16	2	40	23	32	82	120(122.4)	890	
	WP											930	
	NR											100(102.0)	820
	N											120(122.4)	690
	NB											120(122.4)	745
	UW											120(122.4)	980
SJT-125	W	125	32	166	M16	2	40	23	32	95	120(122.4)	1040	
	WP											990	
	GU											120(122.4)	860
												Urethane wheel with nylon wheel assembly (including B)	

- For casters having wheel diameter of $\phi 100$, there are types in which mounting height is 138mm.
- The rubber wheel with conductive steel plate wheel assembly (including B) and the urethane wheel with antistatic steel plate wheel assembly (including B) having wheel diameter of $\phi 100$ can be manufactured.
- Allowable load is the allowable load when the stem is screwed in to the end.
- ★ Refer to P7 for the mounting method.

Wheel in use

Refer to P154 for detailed specifications.



W

Rubber wheel with steel plate wheel assembly (including B)



WP

Steel plate wheel Rubber wheel



NR

Rubber wheel with nylon wheel assembly (including B)



N

Nylon wheel



NB

Nylon wheel (including B)

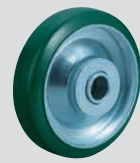

UW

Urethane wheel with steel plate wheel assembly (including B)



GU

Urethane wheel with nylon wheel assembly (including B)