

Unit No. and Dimensions of Nut-series: HN, HNL (for Withdrawal Sleeve)

取りはずしスリーブ用ナット

Nuts for Withdrawal Sleeve

Series HN, HNL

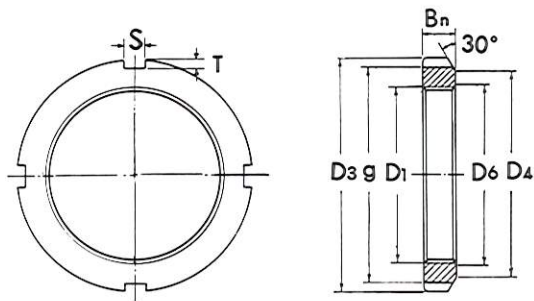

ナット系列HN Nut Series HN

呼び番号 Nominal No.	主要寸法 Boundary Dimension (mm)							
	ネジ呼び(D ₁)×ピッチ Screw (D ₁)×Pitch	D ₃	D ₄	g	S	T	D ₆	B _n
HN 42	TM 210×4	270	238	250	20	10	212	30
44	220×4	280	250	260	20	10	222	32
48	240×4	300	270	280	20	10	242	34
HN 52	TM 260×4	330	300	306	24	12	262	36
58	290×4	370	330	346	24	12	292	40
62	310×5	390	350	366	24	12	312.5	42
HN 66	TM 330×5	420	380	390	28	15	332.5	52
70	350×5	450	410	420	28	15	352.5	55
74	370×5	470	430	440	28	15	372.5	58
HN 80	TM 400×5	520	470	484	32	18	402.5	62
84	420×5	540	490	504	32	18	422.5	70
88	440×5	560	510	520	36	20	442.5	70
HN 92	TM 460×5	580	540	540	36	20	462.5	75
96	480×5	620	560	580	36	20	482.5	75
102 ㊦	510×6	650	590	604	40	23	513	80
HN 106	TM 530×6	670	610	624	40	23	533	80
110	550×6	700	640	654	40	23	553	80

ナット系列HNL 1) Nut Series HNL 1)

HNL 41	TM 205×4	250	232	234	18	8	207	30
43	215×4	260	242	242	20	9	217	30
47	235×4	280	262	262	20	9	237	34
HNL 52	TM 260×4	310	290	290	20	10	262	34
56	280×4	330	310	310	24	10	282	38
60	300×4	360	336	336	24	12	302	42
HNL 64	TM 320×5	380	356	356	24	12	322.5	42
69	345×5	410	384	384	28	13	347.5	45
73	365×5	430	404	404	28	13	367.5	48
HNL 77	TM 385×5	450	422	422	28	14	387.5	48
82	410×5	480	452	452	32	14	412.5	52
86	430×5	500	472	472	32	14	432.5	52
HNL 90	TM 450×5	520	490	490	32	15	452.5	60
94	470×5	540	510	510	32	15	472.5	60
98	490×5	580	550	550	36	15	492.5	60
HNL 104	TM 520×6	600	570	570	36	15	523	68
108	540×6	630	590	590	40	20	543	68

【注】1) HNLは取りはずしスリーブ系列AH30, AH2に使用します。

TMはメートル系30°台形ネジを、数字はネジの外径およびピッチを示したものです。

N.B-1) HNL are used for Withdrawal Sleeve-series AH30, AH2.

TM shows metric 30° Trapezoidal Screw Threads and numeral shows Thread outer diameter and pitch.