

SJC Series Zero Backlash Jaw Coupling

Please, download CAD DATA from www.sungilfa.com

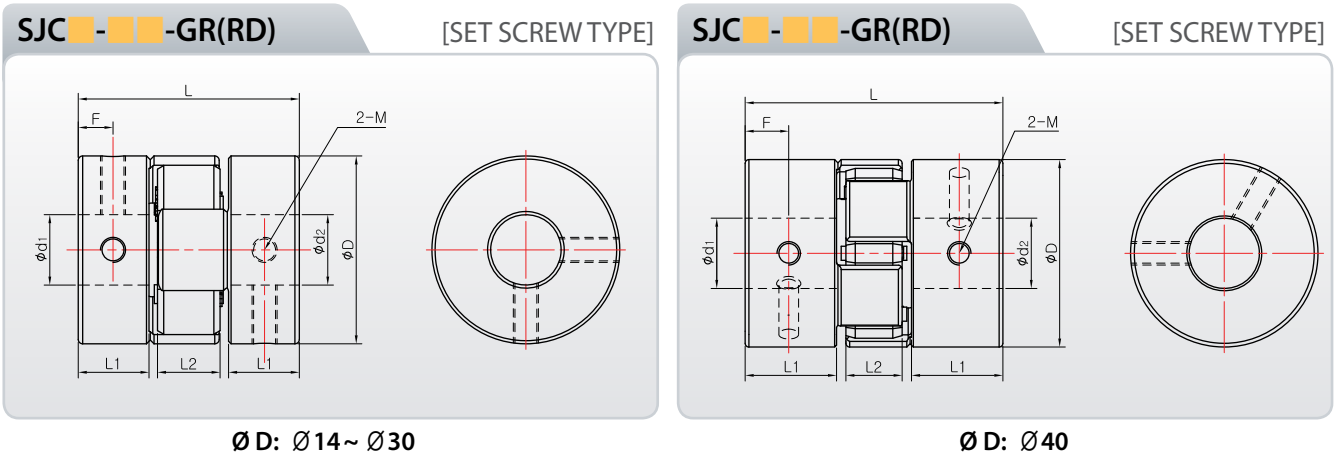

Dimensions & Performance

Product Number	Dimension (mm)(±0.3)					Fastening Bolt M	Fastening Torque (N·m)	Max. RPM (min ⁻¹)	Max Torque (N·m)	Rated Torque (N·m)	Torsional Stiffness (N·m/rad)	Moment of Inertia (kg·m ²)	Mass (g)	Permissible Misalignment		
	D	L	L ₁	L ₂	F									Angle (°)	Parallel (mm)	End-Play (mm)
SJC-14 GR	14	22	7	6	3.45	M3	0.7	27,000	3.2	1.6	20	1.9×10 ⁻⁷	6.7	1.0	0.05	+0.6 -0.2
SJC-20 GR	20	30	10	8	4.65	M3	0.7	19,000	8	4	40	1.0×10 ⁻⁶	18.3	1.0	0.07	+0.8 -0.3
SJC-25 GR	25	31.25	10	9	4.95	M4	1.7	15,000	16	8	180	2.7×10 ⁻⁶	30	1.0	0.07	+1.0 -0.4
SJCA-30 GR	30	35.3	11.3	10	5.55	M4	1.7	13,000	20	10	180	6.2×10 ⁻⁶	46	1.0	0.08	+1.0 -0.4
SJCB-30 GR	30	44.7	16	10	7.25	M4	1.7	13,000	20	10	180	8.2×10 ⁻⁶	60	1.0	0.08	+1.0 -0.4
SJCA-40 GR	40	55	19.5	12	9.3	M5	4	9,600	32	16	1,200	3.3×10 ⁻⁵	132	1.0	0.06	+1.2 -0.5
SJCB-40 GR	40	66	25	12	11.6	M5	4	9,600	32	16	1,200	4.0×10 ⁻⁵	163	1.0	0.06	+1.2 -0.5
SJC-14 RD	14	22	7	6	3.45	M3	0.7	27,000	4	2	30	2.1×10 ⁻⁷	6.7	1.0	0.03	+0.6 -0.2
SJC-20 RD	20	30	10	8	4.65	M3	0.7	19,000	10	5	65	1.0×10 ⁻⁶	18.4	1.0	0.05	+0.8 -0.3
SJC-25 RD	25	31.25	10	9	4.95	M4	1.7	15,000	20	10	220	2.4×10 ⁻⁶	30	1.0	0.05	+1.0 -0.4
SJCA-30 RD	30	35.3	11.3	10	5.55	M4	1.7	13,000	28	14	220	5.9×10 ⁻⁶	46	1.0	0.06	+1.0 -0.4
SJCB-30 RD	30	44.7	16	10	7.25	M4	1.7	13,000	28	14	220	7.2×10 ⁻⁶	60	1.0	0.06	+1.0 -0.4
SJCA-40 RD	40	55	19.5	12	9.3	M5	4	9,600	36	18	2,000	3.1×10 ⁻⁵	132	1.0	0.04	+1.2 -0.5
SJCB-40 RD	40	66	25	12	11.6	M5	4	9,600	36	18	2,000	4.0×10 ⁻⁵	163	1.0	0.07	+1.2 -0.5

* Mass and mass moment of inertia are measured with max. bore size

Standard Inner diameter

Product Number	Standard Inner Diameter(d ₁ , d ₂ , unit:mm)																	
	3	4	4.5	5	6	6.35	7	8	9.525	10	11	12	14	15	16	18	19	20
SJC-14	●	●	●	●														
SJC-20		●	●	●	●	●	●	●										
SJC-25				●	●	●	●	●	●	●								
SJC-30					●	●	●	●	●	●	●	●	●					
SJC-40								●	●	●	●	●	●	●	●	●		

- For the inner diameter, INCH type is available
- Nonstandard inner diameter is also available
- Keyway is available
- The recommendation for shaft tolerance is h7.