

## SHF Type

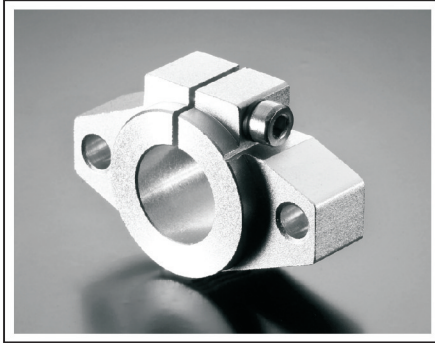

Part number structure example

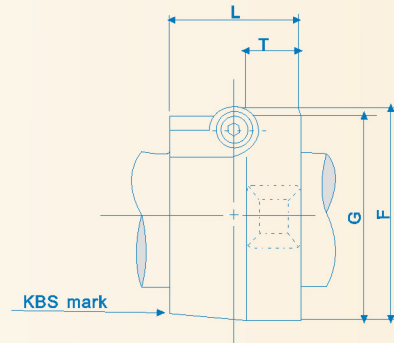
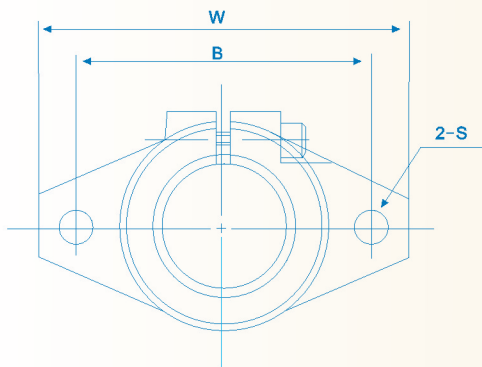
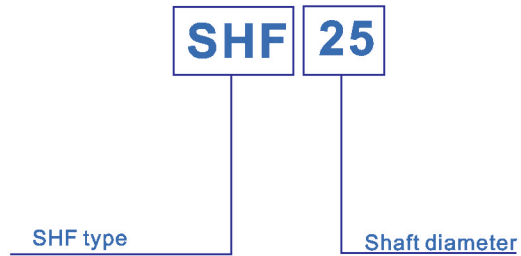

Part Number	Shaft Diameter mm	Major Dimensions							Adjusting Bolt Size	Wgt. g
		W mm	L mm	T mm	F mm	G mm	B mm	S (Bolt Size) mm		
SHF 10	10	43	10	5	24	20	32	5.5(M5)	M 4	13
SHF 12	12	47	13	7	28	25	36	5.5(M5)	M 4	20
SHF 13	13	47	13	7	28	25	36	5.5(M5)	M 4	20
SHF16	16	50	16	8	31	28	40	5.5(M5)	M 4	27
SHF 20	20	60	20	8	37	34	48	7(M6)	M 5	40
SHF 25	25	70	25	10	42	40	56	7(M6)	M 5	60
SHF 30	30	80	30	12	50	46	64	9(M8)	M 6	110
SHF 35	35	92	35	14	58	50	72	12(M10)	M 8	380
SHF 40	40	102	40	16	67	56	80	12(M10)	M 10	510
SHF 50	50	122	50	19	83	70	96	14(M12)	M 12	890
SHF 60	60	140	60	23	95	82	112	14(M12)	M 12	1,500