

700Z

Valve nominal size

40 to 300mm

Max. working pressure MPa

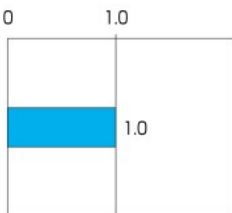

Working temperature range °C

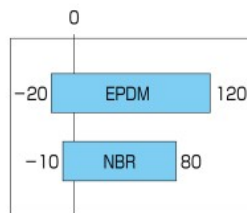

JIS JIS B 2032 Compliant
(This product conforms to General Specifications for Machinery and Equipment of the Ministry of Land, Infrastructure, Transport and Tourism.)

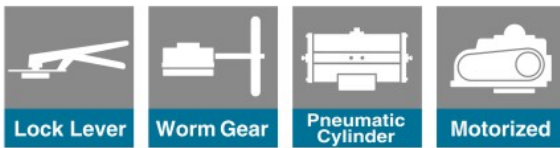

Evolution of Long Sellers Sealing performance and Durability Improved!

- Gears and lever have been integrated with valve body to achieve both functionality and downsizing.
- Resin-aluminum hybrid gearbox improves the strength and durability of valves with anti-condensation performance added.
- High anti-condensation performance of the Z series has been inherited. (Gear valves)
- New lightweight valve disc with optimized seal shape improves the sealing performance and operability of valves.
- Modified rubber seat structure stabilizes the sealing performance of valve seat.
- Strong bearings have been adopted to significantly improve the durability of valve opening/closing. (Automatic valves)
- Special valve body has been developed for automatic valves to improve their strength and durability.

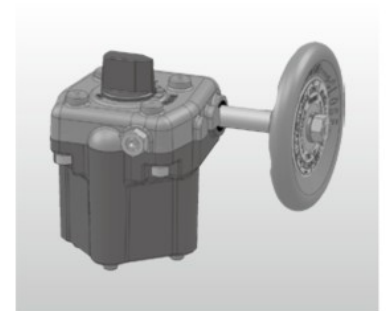

***Note : These valves are different in face-to-face dimensions from the first 700Z (Coating color: Light blue; Munsell 10BG-6/4) developed in 1980 and discontinued in August 2003.**