

AGM dimensions

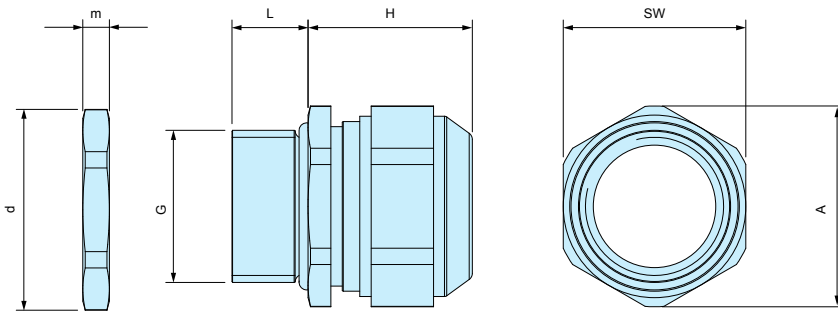

Part no. / Dimensions

Part no.	G		Cable range		L	H Max	SW	A	d	m	Sales unit
	Thread size	Mounting hole	Min	Max							
AGM 6-2.5	M6×1.0	Φ6.2	2	2.5	8	12	8	9	10	2.8	1
AGM 6-3	M6×1.0	Φ6.2	2.5	3.0	8	12	8	9	10	2.8	1
AGM 6-3.5	M6×1.0	Φ6.2	3.0	3.5	8	12	8	9	10	2.8	1
AGM 8-5	M8×1.25	Φ8.2	3.5	4.7	10	14	11	12	12	3	1
AGM10-6	M10×1.5	Φ10.2	4.0	6.0	10	15	13	14.3	14	2.8	1
AGM12-8	M12×1.5	Φ12.2	6.5	8.0	10	17	15	16.5	16.5	2.8	1
AGM16-10.5	M16×1.5	Φ16.2	8.0	10.5	10	21	18	20	21	3	1
AGM20-15	M20×1.5	Φ20.2	11.0	15.0	10	23	24	26.5	26.5	3.5	1
AGM25-20	M25×1.5	Φ25.2	16.0	20.0	11	28	30	33	33	4	1
AGM32-25.5	M32×1.5	Φ32.3	21.0	25.5	13	29.5	36	39.5	39.5	4	1
AGM40-28.5	M40×1.5	Φ40.3	24.0	28.5	13	32	46	50.7	51	5	1
AGM40-33	M40×1.5	Φ40.3	28.5	33.0	13	32	46	50.7	51	5	1
AGM50-37	M50×1.5	Φ50.4	33.0	37.0	14	34	55	59.7	60	5.5	1
AGM50-42	M50×1.5	Φ50.4	37.0	42.0	14	34	55	59.7	60	5.5	1
AGM 7PG-5	PG 7	Φ12.7	3.5	5.0	6	17	15	16.5	16.5	3	1
AGM 9PG-6	PG 9	Φ15.4	4.5	6.0	6	20	18	20	20	3	1
AGM11PG-8.5	PG11	Φ18.8	5.5	8.5	6	21	21	23	23.5	3	1
AGM13PG-11	PG13	Φ20.6	8.0	11.0	6	21	24	26.5	25.5	3	1
AGM16PG-14.5	PG16	Φ22.7	11	14.5	6	23	24	26.5	29	3	1

APPLICATION EXAMPLE

