

Rake Angle	Radial	+2°
	Axial	+8°

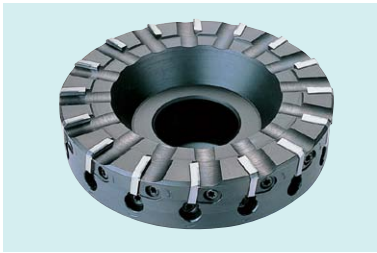

High-speed Finishing for Grey Cast Iron



- Specially designed for use with SUMIBORON BN700 in the high speed milling of Grey Cast Iron

Body

Inch

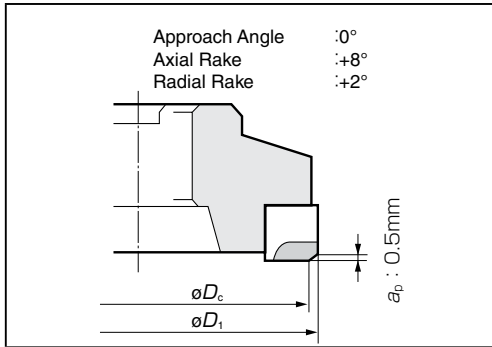

Structure

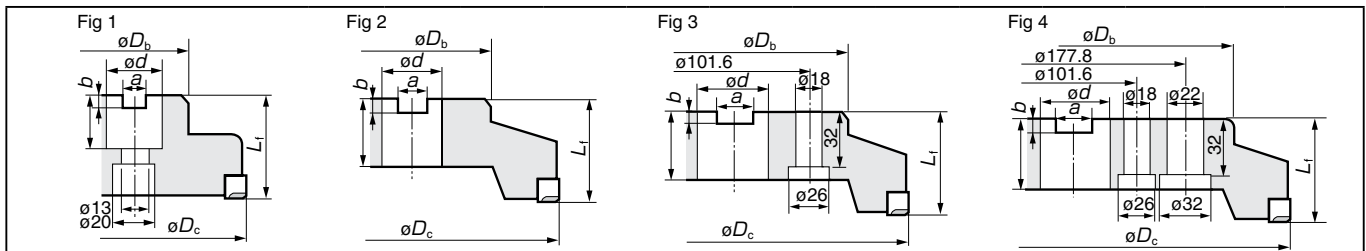
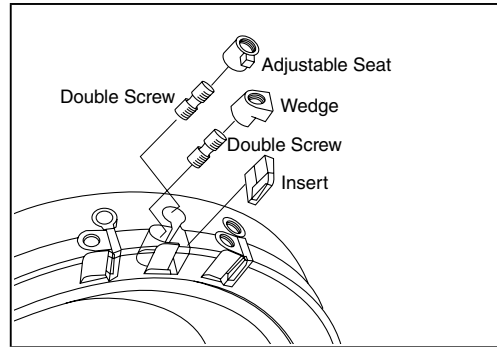

Cat. No.	Stock		Dimensions (mm)								No. of teeth	Weight (kg)	Fig
	R	L	ϕD_c	ϕD_1	ϕD_b	L_f	ϕd	a	b	ϕ			
FM 5080 R/L	●		80	82.8	60	50	25.4	9.5	6	25	6	1.6	1
5100 R/L	●		100	102.8	75	50	31.75	12.7	8	32	8	2.4	2
5125 R/L	●		125	127.8	75	63	38.1	15.9	10	38	10	3.4	2
5160 R/L	●		160	162.8	100	63	50.8	19.0	11	38	12	5.6	2
5200 R/L			200	202.8	130	63	47.625	25.4	14	40	16	8.3	3
5250 R/L			250	252.8	130	63	47.625	25.4	14	40	20	14.3	3
5315 R/L			315	317.8	240	80	47.625	25.4	14	40	24	27.8	4
FMF 5125 R/L			125	127.8	75	63	38.1	15.9	10	38	12	3.4	2
5160 R/L			160	162.8	100	63	50.8	19.0	11	38	16	5.6	2
5200 R/L			200	202.8	130	63	47.625	25.4	14	40	20	8.3	3
5250 R/L			250	252.8	130	63	47.625	25.4	14	40	24	14.3	3
5315 R/L			315	317.8	240	80	47.625	25.4	14	40	28	27.8	4

Inserts are not included.

Insert

Cat. No.	Stock				Fig
	BN7000		BN700		
	R	L	R	L	
SNEN 1504ADT R/L	●		●		1
1504ADT R/L-S	●		●		2

* -S denotes low cutting force insert

Parts

						Applicable Cutter
Wedge	Adjustable Seat	Adjustment Screw	Double Screw	Wrench	Wrench	
FMW	— FME	FMJ —	WB7F-20TL	TT25	1.8 x 45 —	FM5080R/L FM5100R/L FM5315R/L