

SEC-Boring Bars S-DDQN/S-DDUN/D-DDUN Type

Copying

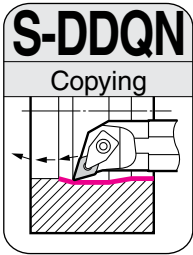

Steel

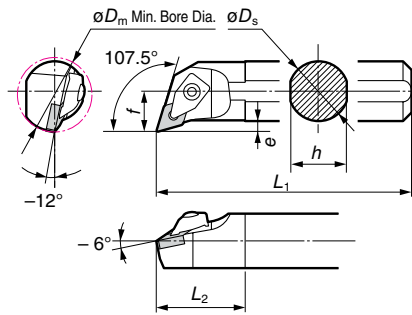

Insert

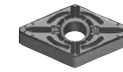

· DNMG150408N-GE
(Representative example)

Spare Parts

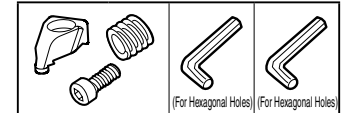

■ Holder Right handed toolholders are applicable with left handed or neutral inserts.
Left handed toolholders are applicable with right handed or neutral inserts.

Above figures show right hand tools.

Shank	Cat. No.	Conventional Cat. No.	Stock		Dimensions (mm)							Applicable Insert		Clamp Set	Recommended Tightening Torque (N·m)	Wrench for Upper Surface	Wrench for Lower Surface
			R	L	ϕD_m	ϕD_s	h	L_1	f	L_2	e	Cat. No.	Featured page				
Steel	S32T-DDQN R/L1504-40	S32T-DDQN R/L15	●	●	40	32	30	300	22	48	6	DN □□1504□□	From B31	SCP-2	5.0	LH040	LH025

Clamp Set Parts E77

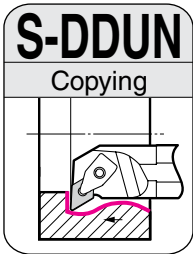

Steel

New

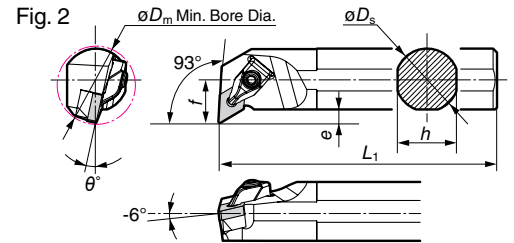
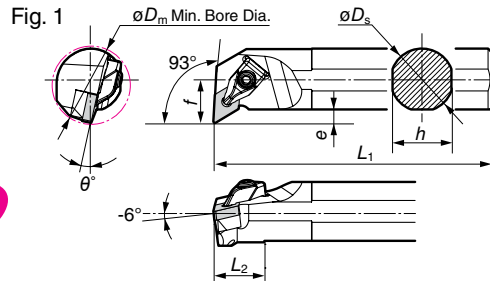

Spare Parts

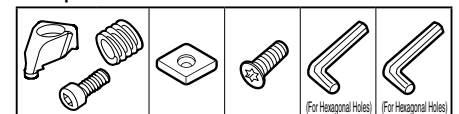

■ Holder Right handed toolholders are applicable with left handed or neutral inserts.
Left handed toolholders are applicable with right handed or neutral inserts.

Above figures show right hand tools.

Shank	Cat. No.	Stock		Dimensions (mm)							Fig.	Applicable Insert		Clamp Set	Recommended Tightening Torque (N·m)	Shim	Shim Screw	Wrench for Upper Surface	Wrench for Lower Surface
		R	L	ϕD_m	ϕD_s	h	L_1	f	L_2	e		Cat. No.	Featured page						
Steel	S32S-DDUN R/L1504-40	●	●	40	32	30	250	22.0	26	7.0	1	DN □□1504□□	From B31	SCP-2	5.0	DNS1504B	BFTX0409N	LH040	LH025
	S40T-DDUN R/L1504-50	●	●	50	40	37	300	27.0	26	8.5									
	S50U-DDUN R/L1504-63	●	●	63	50	47	350	31.5	—	8.0									

Clamp Set Parts E77

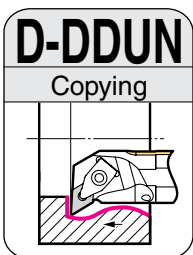

Anti-vibration with oil hole

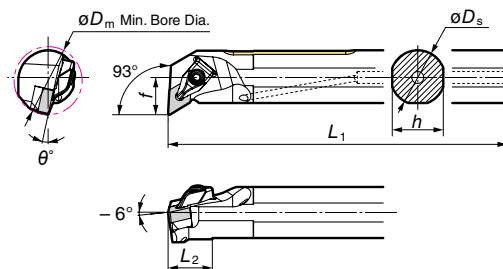

Insert

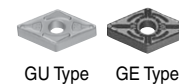

SumiTura Bar

· DNMG110404N-GU
· DNMG150604N-GE
(Representative example)

Spare Parts

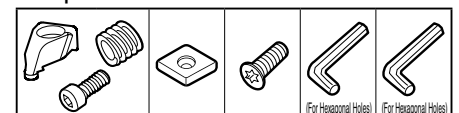

■ Holder Right handed toolholders are applicable with left handed or neutral inserts.
Left handed toolholders are applicable with right handed or neutral inserts.

Above figures show right hand tools.

Shank	Cat. No.	Stock		Dimensions (mm)							Applicable Insert	Clamp Set	Recommended Tightening Torque (N·m)	Shim	Shim Screw	Wrench for Upper Surface	Wrench for Lower Surface	
		R	L	ϕD_m	ϕD_s	h	L_1	f	L_2	θ°								Cat. No.
Anti-vibration with oil hole	D32T-DDUN R/L1104-40	●	●	40	32	30	300	22	26	-10	DN □□1104□□	B30	SCP-1	5.0	DNS1104B	BFTX0307N	LH040	LH025
	D32T-DDUN R/L1506-40	●	●	40	32	30	300	22	26	-12								
	D40U-DDUN R/L1506-50	●	●	50	40	37	350	27	26	-12								

Clamp Set Parts E77

E Boring Bars