

# SEC-Boring Bars S-SDQC/B-SDQC Type

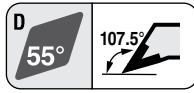

## Internal Copying

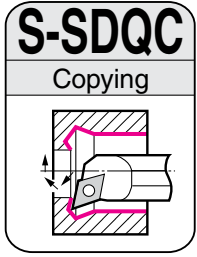

**Steel**

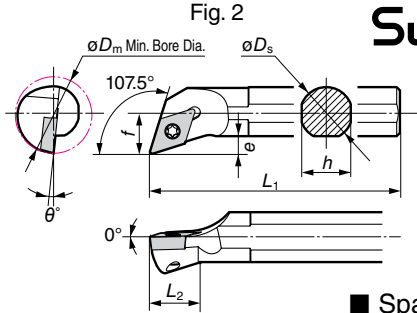
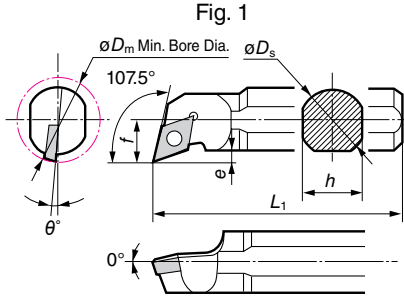

**SumiSmall**

### ■ Spare Parts

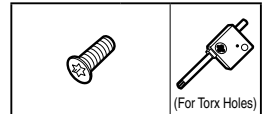

■ Holder Right handed toolholders are applicable with left handed or neutral inserts.  
Left handed toolholders are applicable with right handed or neutral inserts.

Above figures show right hand tools.

Shank	Cat. No.	Conventional Cat. No.	Stock		Dimensions (mm)							Fig.	Applicable Insert	Screw	Recommended Tightening Torque (N·m)	Wrench	
			R	L	$\theta D_m$	$\theta D_s$	$h$	$L_1$	$f$	$e$	$\theta^\circ$						$L_2$
Steel	S10M-SDQC R/L0702-13	S10M-SDQC R/L07	●	●	13	10	9	150	7.0	2.5	-8	—	1	DC □□0702□□	BFTX02506N	1.5	TRX08
	S12M-SDQC R/L0702-16	S12M-SDQC R/L07	●	●	16	12	11	150	9.0	3.5	-8	—					
	S16Q-SDQC R/L0702-20	—	●	●	20	16	15	180	11.0	4.0	-6	—					
	S16N-SDQC R/L0702-20	S16N-SDQC R/L07	●	●	20	16	15	160	11.0	4.0	-6	—					
	S16Q-SDQC R/L11T3-23	—	●	●	23	16	15	180	12.5	5.5	-6	15	2	DC □□11T3□□	BFTX0409N	3.4	TRX15
	S20R-SDQC R/L11T3-25	—	●	●	25	20	18	200	13.0	4.5	-6	—					
	S20N-SDQC R/L11T3-25	S20N-SDQC R/L11	●	●	25	20	18	160	13.0	4.5	-6	—					
	S25S-SDQC R/L11T3-32	—	●	●	32	25	22	250	17.0	7.0	-6	—					
S25Q-SDQC R/L11T3-32	S25Q-SDQC R/L11	●	●	32	25	22	180	17.0	7.0	-6	—	1					

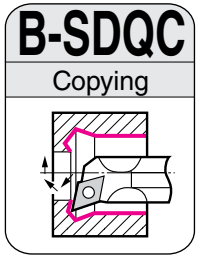

**Anti-vibration**

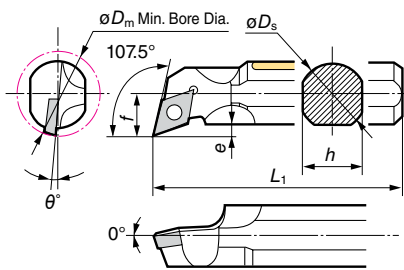

**SumiTurn** *Bar*

**SumiSmall**

### ■ Spare Parts

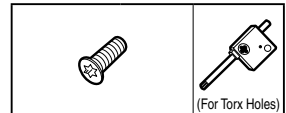

■ Holder Right handed toolholders are applicable with left handed or neutral inserts.  
Left handed toolholders are applicable with right handed or neutral inserts.

Above figures show right hand tools.

Shank	Cat. No.	Stock		Dimensions (mm)							Applicable Insert	Screw	Recommended Tightening Torque (N·m)	Wrench
		R	L	$\theta D_m$	$\theta D_s$	$h$	$L_1$	$f$	$e$	$\theta^\circ$				
Anti-vibration	B10M-SDQC R/L0702-13	●	●	13	10	9	150	7	2.5	-8	DC □□0702□□	BFTX02506N	1.5	TRX08
	B12M-SDQC R/L0702-16	●	●	16	12	11	150	9	3.5	-8				
	B16R-SDQC R/L0702-20	●	●	20	16	15	200	11	4.0	-6				
	B20S-SDQC R/L11T3-25	●	●	25	20	18	250	13	4.5	-6	DC □□11T3□□	BFTX0409N	3.4	TRX15
	B25S-SDQC R/L11T3-32	●	●	32	25	22	250	17	7.0	-6				