

# Fine boring unit

## Unit and Cartridge



KAPR  
DSGN

90°  
2

90°  
1

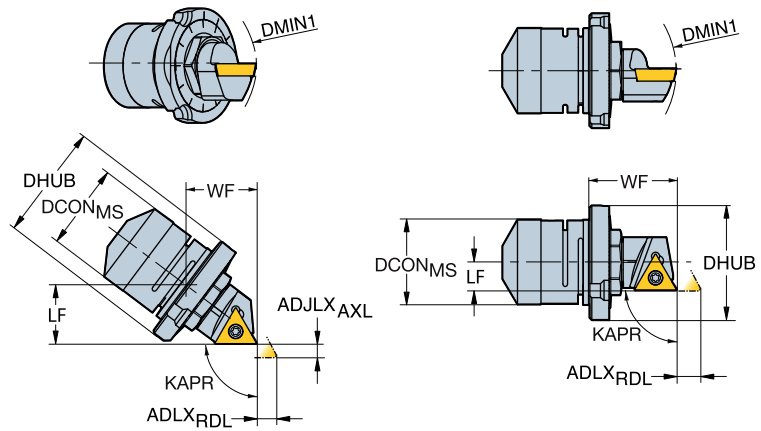

						Dimensions, mm, inch						MIID	
DMIN <sub>1</sub>			CZC <sub>MS</sub>	CNSC	DSGN	Ordering code	DCON	ADJLXRDL	LF	WF			
24.8	06	1/4	1	0	2	L148C-31-0602	16.00	2.00	8.40	11.20	0.6	0.550	CCMT 06 02 00 RE=0
.976							.630	.079	.331	.441			CCMT 2(1.5)0 RE=0
24.8	06	5/32	1	0	2	L148C-31-06T1	16.00	2.00	8.30	11.10	0.6	0.054	TCMT 06 T1 00 RE=0
.976							.630	.079	.327	.437			TCMT 1.2(1.2)0 RE=0
27.0	06	1/4	1	0	1	R/L148C-11-0602	16.00	2.50	5.10	12.90	0.6	0.060	CCMT 06 02 00 RE=0
1.063							.630	.098	.201	.508			CCMT 2(1.5)0 RE=0
36.5	09	7/32	2	0	1	R/L148C-12-0902	20.00	3.50	6.30	18.30	0.8	0.054	TCMT 09 02 00 RE=0
1.437							.787	.138	.248	.720			TCMT 1.8(1.5)0 RE=0
32.5	09	7/32	2	0	2	R/L148C-32-0902	20.00	2.80	11.50	15.30	0.6	0.060	TCMT 09 02 00 RE=0
1.280							.787	.110	.453	.602			TCMT 1.8(1.5)0 RE=0
48.5	11	1/4	3	0	1	R/L148C-13-11 03	22.00	6.00	7.20	22.10	0.9	0.093	TCMT 11 03 04
1.909							.866	.236	.283	.870			TCMT 221
48.5	11	1/4	3	0	1	R/L148C-13-1102	22.00	6.00	7.20	22.10	0.9	0.093	TCMT 11 02 00 RE=0
1.909							.866	.236	.283	.870			TCMT 2(1.5)0 RE=0
42.0	11	1/4	3	0	2	R/L148C-33-11 03	22.00	4.80	14.10	18.70	0.8	0.095	TCMT 11 03 04
1.654							.866	.189	.555	.736			TCMT 221
42.0	11	1/4	3	0	2	R/L148C-33-1102	22.00	4.80	13.80	18.40	0.9	0.040	TCMT 11 02 00 RE=0
1.654							.866	.189	.543	.724			TCMT 2(1.5)0 RE=0
69.0	16	3/8	4	0	1	R/L148C-14-16T3	32.00	10.00	10.30	32.00	3.0	0.355	TCMT 16 T3 00 RE=0
2.717							1.260	.394	.406	1.260			TCMT 3(2.5)0 RE=0
60.0	16	3/8	4	0	2	R/L148C-34-16T3	32.00	8.00	20.00	26.70	0.9	0.474	TCMT 16 T3 00 RE=0
2.362							1.260	.315	.787	1.051			TCMT 3(2.5)0 RE=0



Q1



Q35