

Amplifier Unit

ZX-TDA11
ZX-TDA41

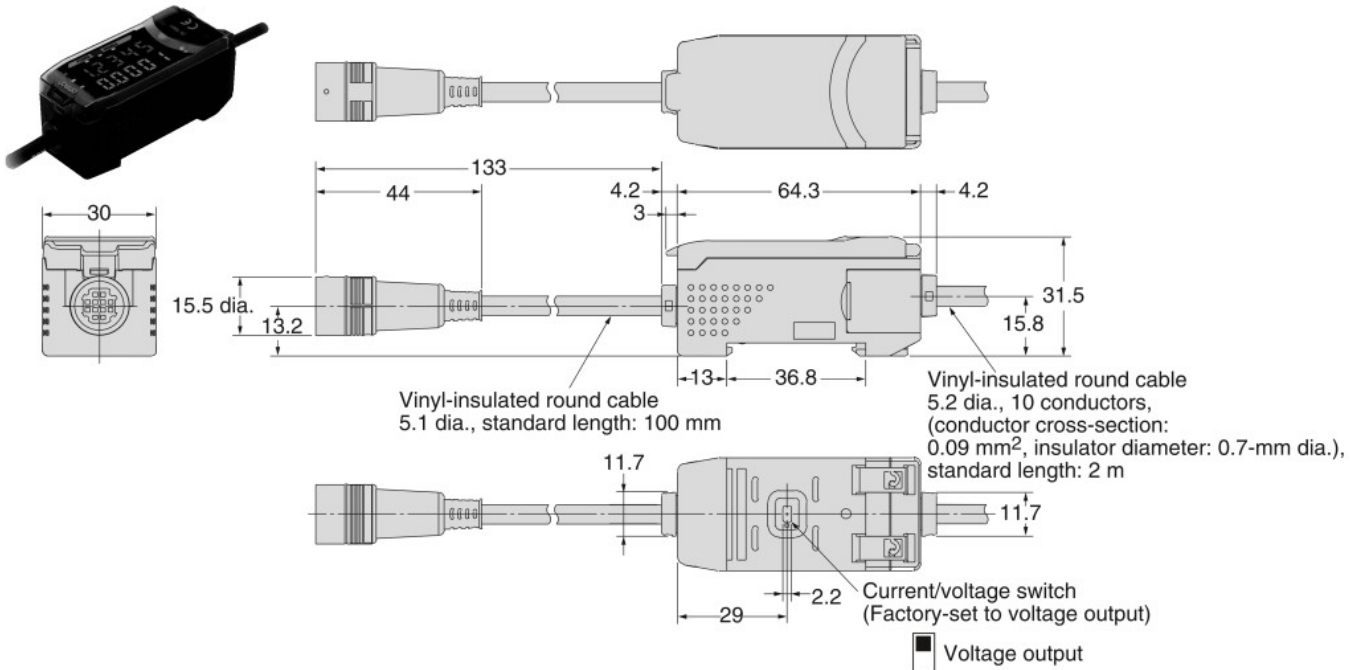

■ Accessories (Order Separately)

Preamplifier Mounting Bracket (Supplied with Each Sensor)

ZX-XBT1

ZX-XBT2 (For DIN Track Mounting)

