



Blade tip materials
Point of a sword materials
Carbide Tip

Effective cutting power
Effective cutting power
35SQ...35mm
50SQ...50mm

size
Size
35SQ...17.5-35.0
50SQ...17.5-65.0

Work material

- Steel plate
- Stainless steel
- Casting Iron
- Aluminum
- Brass / Copper

Compatible machine types
Acceptable model

- Flatter
- Magnetic hand drills
- Drill press machine
- Radial drill press machine
- Lath machine
- Milling Machine

Mode
Mode



※ With the exception of the dedicated model, a dedicated shank is required.

Product specification diagram

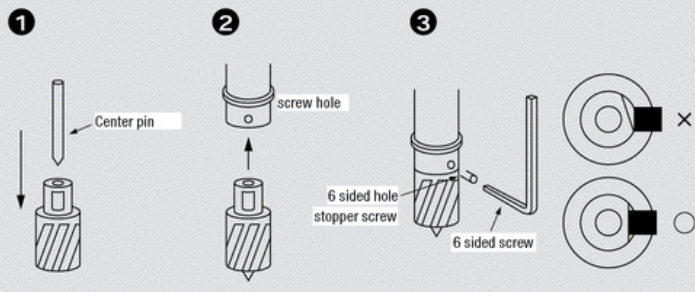
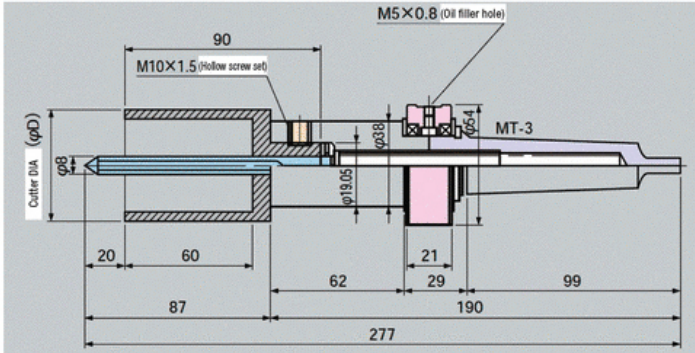
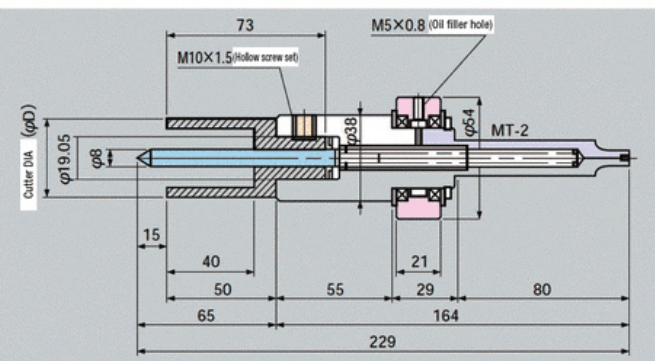

If hollow screw set assembly is wrong then due to cracks in the hollow screw set there are cases where cutter will not come out. It also becomes the reason for the chipping accumulation.