

Reamers

Endmills

Drills

Countersinks/  
Counterbores

Slitting Saws/  
Cut-off tools

Cutters

Side  
Milling

Staggered

Angle

Plain

for Pipe

# PPC

パイカッター  
PIE CUTTER



- パイプ材のえぐり加工に使用  
Used for processing scooping out
- MCO材(コバルト高速度鋼)を使用  
Uses MCO material (Cobalt high-speed steel)

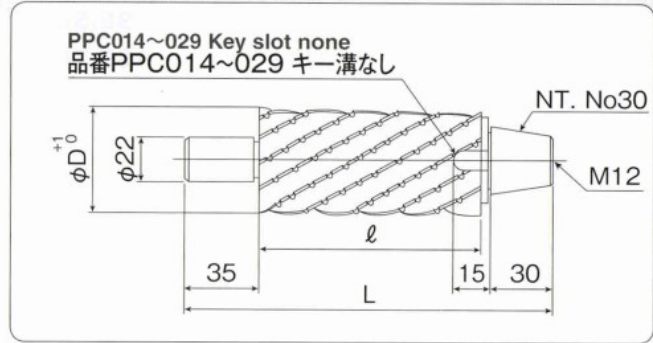

品番 Product No.	寸法 Size				標準価格 Standard price ¥
	刃径 D	刃長 ℓ	全長 L	刃数 NT	
PPC014	14	110	180	6	67,800
PPC017	17	110	180	6	67,800
PPC020	20	110	180	8	67,800
PPC022	22	110	180	8	67,800
PPC023	23	110	180	8	67,800
PPC026	26	110	180	10	67,800
PPC028	28	110	180	10	67,800
PPC029	29	110	180	10	74,300
PPC033	33	110	180	10	74,300
PPC035	35	110	180	12	76,300
PPC039	39	110	180	14	78,400
PPC0435	43.5	110	180	14	88,900
PPC050	50	110	180	16	105,900
PPC052	52	110	180	16	110,000
PPC060	60	110	180	20	148,100
PPC062	62	110	180	20	156,600
PPC078	78	130	200	22	380,400
PPC092	92	130	200	26	507,000
PPC104	104	130	200	28	528,300
PPC116	116	130	200	32	633,900

### パイプ材サイズ表 Size of pipe

パイプ外径 Pipe Dia. (mm)	ガス管 呼び Nominal size of gas tube	パイカッター外径 Dia. of PIE CUTTER D(mm)
12.7		14
13.0		
13.8	8A	
15.9		17
16.0		
17.3	10A	20
19.0		
19.1		
21.7	15A	22
22.0		23
22.2		26
25.0		
25.4		28
27.2	20A	
28.6		29
31.8		33
32.0		
34.0	25A	35
36.0		
38.1		39
42.7	32A	
48.6	40A	43.5
50.0		
50.8		50
60.5	50A	
60.5		62
76.3	65A	
89.1	80A	78
101.6	90A	
114.3	100A	92
		104
		116

### ■使用例 Use example

えぐり加工 Processing scooping out

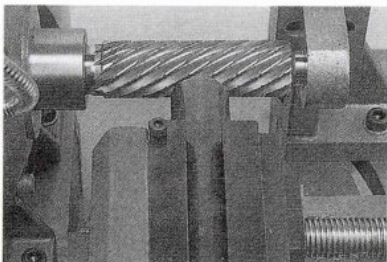

丸パイプ  
Round pipe



角パイプ  
Square pipe

角度えぐり加工 Processing scooping out with angle

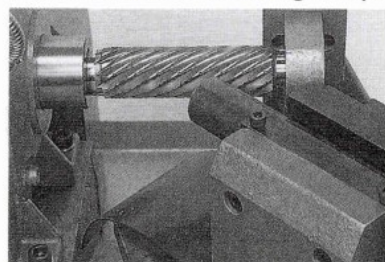

丸パイプ  
Round pipe



角パイプ  
Square pipe