

Product Specifications

Standard Specifications

Outer and Inner Rings	AISI 440C
Ball *1	AISI 440C
Retainer	AISI 304
Shield	AISI 304
Setscrew	AISI 304 equivalent
Lubricant *2	Heat-resistant grease

Special specifications also available

*1 Ceramic balls(Silicon Nitride Si₃N₄)

*2 Heat- and chemical-resistant fluorine grease, food grade grease, and other special grease

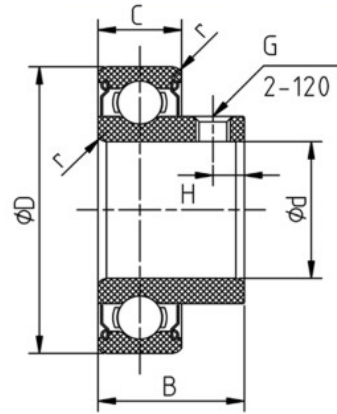

Dimensions

Bearing Numbers	d		D	B	C	G	H	r min	Cr	C0r
	mm	Tolerance								
SS XC900 ZZ	10		22	13	6	M3	3.0	0.3	2700	1270
SS XC000 ZZ	10		26	15	8	M3	3.0	0.3	4600	1970
SS XC200 ZZ	10		30	17	9	M4	3.5	0.6	5100	2390
SS XC901 ZZ	12	+0.015 0	24	13	6	M3	3.0	0.3	2890	1460
SS XC001 ZZ	12		28	15	8	M3	3.0	0.3	5100	2390
SS XC201 ZZ	12		32	19	10	M4	3.5	0.6	6800	3050
SS XC902 ZZ	15		28	14	7	M3	3.0	0.3	4300	2250
SS XC002 ZZ	15		32	16.5	9	M3	3.0	0.3	5600	2840
SS XC202 ZZ	15		35	20	11	M4	3.5	0.6	7650	3750
SS XC903 ZZ	17		30	14	7	M3	3.0	0.3	4600	2550
SS XC003 ZZ	17		35	17.5	10	M4	3.5	0.3	6000	3250
SS XC203 ZZ	17		40	21	12	M5	4.5	0.6	9600	4800
SS XC904 ZZ	20	+0.018 0	37	18	9	M4	3.5	0.3	6400	3700
SS XC004 ZZ	20		42	21	12	M5	4.5	0.6	9400	5050
SS XC204 ZZ	20		47	23	14	M5	4.5	1.0	12800	6650
SS XC905 ZZ	25		42	18	9	M4	3.5	0.3	7000	4550
SS XC005 ZZ	25	47	22	12	M5	4.5	0.6	10100	5850	
SS XC205 ZZ	25	52	26	15	M5	4.5	1.0	14000	7900	
SS XC906 ZZ	30		47	18	9	M4	3.5	0.3	7250	5000
SS XC006 ZZ	30		55	24.5	13	M5	5.0	1.0	13200	8300
SS XC206 ZZ	30		62	28.5	16	M6	5.5	1.0	19500	11300
SS XC207 ZZ	35	+0.021 0	72	33	17	M6	6.5	1.1	25700	15400

Precautions

Please refer to the chart for the tightening torque. Too much torque may damage the bearing. Adhesive bond is not recommended that may increase the tightening force and result in the breakage of bearing.

Recommended tightening torque

Setscrew size	Tightening torque N·m
M3	0.7
M4	1.8
M5	3.0
M6	4.0

*The performance data and expressions are provided as a general guide only.

The specifications are subject to change without notice for the improvement of performance.

SMT

Nankai Seiko Co., Ltd.

3-6-1, Techno Stage, Izumi, Osaka 594-1144, Japan.

TEL 0725-53-5563 FAX 0725-53-5576

URL <http://www.smtbearing.com>