

BEAM TRAMMEL WITH CARBIDE TIP

For scribing circle of large diameter

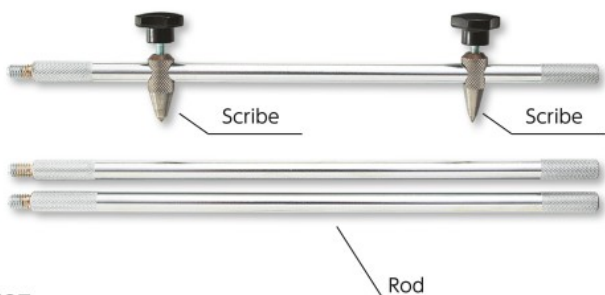

USE

- For scribing

MATERIAL

- Rod: Carbon tool steel (nickel plated)
- Scriber: Stainless steel

FEATURES

- For scribing work
- Three rods connected can scribe circle of dia. approx. 1.5m max.
- Includes three rods
- Additional rod available (separately sold): Up to four rods can be connected

Order No.	Model No.	Outside Diameter (mm)	Weight
000100	BT-13	10	800g

ATTACHMENT SCRIBER FOR CALIPER

Mounting on caliper for scribing▶

Caliper

P162
~183

Rust prevention▶

Zerust Film for Steel

P380



※ Caliper is not included

USE

- Mounting on caliper for scribing

MATERIAL

- Body: Carbon steel (black oxide coated)
- Tip: Carbide tipped (G2)

FEATURES

- Attach to the jaw of calipers for accurate scribing

ACCESSORIES

- Hex wrench

Order No.	Model No.	Applicable caliper size	Length (mm)	Groove Width (mm)	Weight
000111	N-10	100mm	36	3.5	100g
000112	N-20	150·200mm	43	4	200g
000113	N-30	250·300mm	72	4.5	500g
000116	N-60	500·600mm	98	7	1.1kg

SCRIBING VERNIER CALIPER



For high precise scribing

※ Please refer to Page 184 for dimensions or detailed specifications for this item

Reference standard for calibration▶

Block Gauge

P42
~49

Rust prevention▶

Zerust Film for Steel

P380

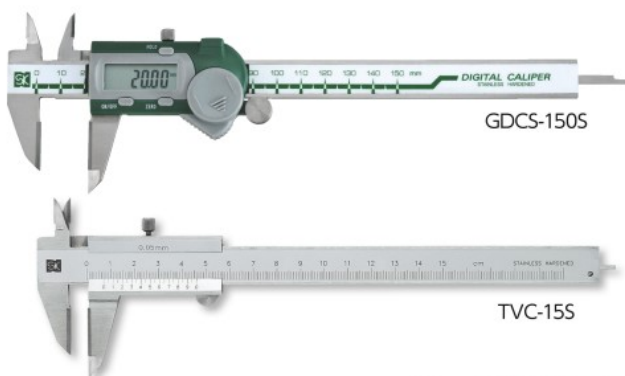

USE

- Outside diameter, inside diameter, step and depth measurement, and also scribing

MATERIAL

- stainless steel

FEATURES

- Carbide-tipped measuring faces

Order No.	Model No.	Measuring Range (mm)	Resolution (mm)	Weight
NEW! 151983	GDCS-150S	0 ~ 150	0.01	170g
151279	TVC-15S		0.05	150g

SCRIBING VERNIER CALIPER



For high precise scribing

※ Please refer to Page 142 for dimensions or detailed specifications for this item

For marking work▶

Scribes

P330
~331

Rust prevention▶

Zerust Film for Steel

P380

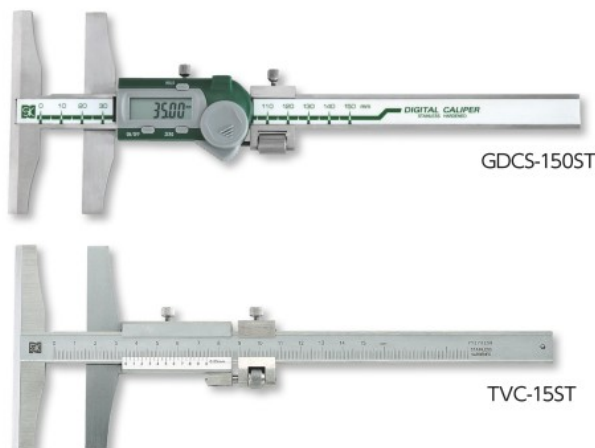

USE

- Measures distance from caliper base to scribe edge

MATERIAL

- Stainless steel

ACCESSORIES

- Carbide tip scriber SC-P

Order No.	Model No.	Measuring Range (mm)	Resolution (mm)	Weight
NEW! 151995	GDCS-150ST	0 ~ 150	0.01	295g
NEW! 151996	GDCS-300ST	0 ~ 300		360g
151803	TVC-15ST	0 ~ 150	0.05	240g
151804	TVC-30ST	0 ~ 300		370g

PUNCH

SCRIBER

POWER SCRIBER

DIVIDER

CALIPER

SURFACE GAUGE