

RNCL Digicollars

WEB Selection
Tool

WEB CAD
Download

Main body

Collar

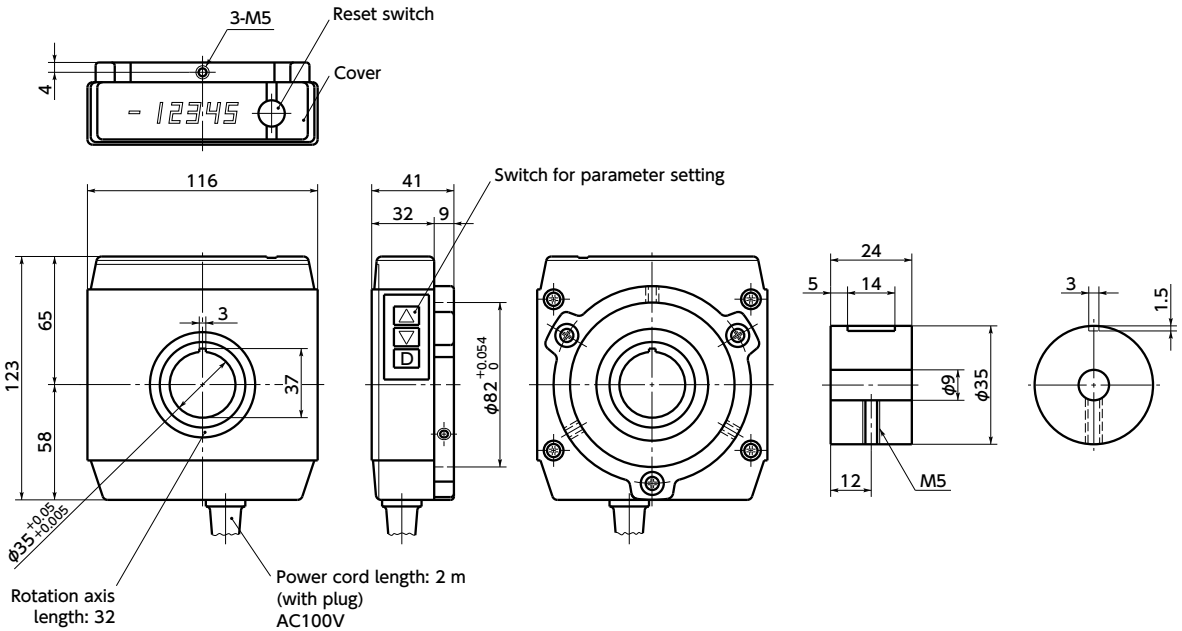

● Performance

Max. Number of Display Digits	Six digits / Red seven segment LED
Range of Count	Length measurement: 999999 ~ -99999 Angle $\pm 360.00^\circ$
Count Mode	Length measurement: Decimal, binary Angle in sexagesimal: 1 / 5 / 10 minute(s) Angle in decimal: 0.01 / 0.1 / 1° for reading
Position of Decimal Point	Custom setting by parameter
Lead Value	Custom setting by parameter
Memory	Nonvolatile memory, backup for 10 years
Max. Allowable Speed	700 min ⁻¹
Power Source	100 V AC $\pm 10\%$ (50 / 60 Hz)
Power Code	With 2 m plug
Power Consumption	2.2 W
Vibration-resistance	49 G for 30 minutes
Shock-resistance	Durability 294 G, three times each for X / Y and Z direction
Range of Allowable Operating Temperature	0°C to 45°C
Range of Storage Temperature	-20°C to 80°C

Part Number	Mass (g)
RNCL-300	900

- Collar (hex socket set screw with key) is provided.

● Usage example

