

EAT Metal Knob

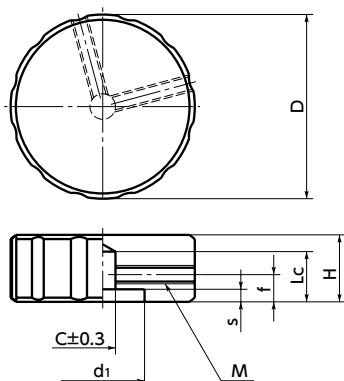

WEB Selection Tool WEB CAD Download



- **EAT-22** **EAT-27** **EAT-33** has symbol marks.

- Material/Finish

RoHS Compliant

EAT	
Main body	Aluminum Alloy Alumite Treatment

Unit : mm

Part Number	D	H	d1	s	f	M (Coarse)	Lc	C	Mass (g)
EAT-22	22	15	16	3	5	1 - M4	13	6.1	12
EAT-27	26.5	17	20	3	6	1 - M4	15	6.1	22
EAT-33	33	17	20	3	7	1 - M4	15	6.1	33
EAT-44	44	16	20	3	6	2 - M4	12	6.1	58

- Hex socket set screw is provided.

- Part number specification

EAT-22



Cleanroom Wash & Packaging → P.792	Screw Combination → P.798	Screw Length Adjustment → P.796	Vibration Resistant → P.795	Laser Marking → P.806
Available / Add'l charge	Not Available	Not Available	Not Available	Available / Add'l charge