

PS604

Joint for additional joint of shaft

14×15×10

PS605,PS606

Joint to use female screw. For parts attachment

14×15×10	
Part No.	M
PS605	5
PS606	6

PS620

The type of installation on the side surface

Fix a stanchion more firmly with using two spots screw and a slotted hole type.

PS720,PS721

Vertical-horizontal hole for frame support or T-shape attachment

Screw cap to be on the opposite side against PS720

PS720

PS721

15×10×14

PS722

Vertical-horizontal hole for frame support or T-shape attachment

15×10×18

BC825S~BC829S

It can be used for installation of a fiber sensor

15×15×40	
Part No.	φP
BC825S	φ2.9
BC826S	φ3.1
BC827S	φ4.1
BC828S	φ5.1
BC829S	φ6.1

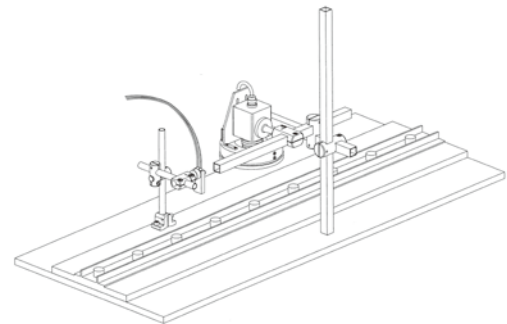

BC851S

Attachment

20×50×14

AB3060A, AB4065A

Complementary base (a processed type with a screw hole for a prompt fixing)

Equipment is more safely fixed with a combination of a stanchion bracket. ◎

It is acceptable for 30mm square aluminum frame. Corresponding part number PS600, PS601, PS602, PS603

It is acceptable for 40mm square aluminum frame. Corresponding part number PS600, PS601, PS602, PS603

AB3060A

Fixation screw for PIJON M3×12-M3×15 Two each attachment 30×60×8

AB4065A

Fixation screw for PIJON M3×12-M3×15 Two each attachment 40×65×10

AB3070, AB4075, AB4090

Complementary base (Non-screw hole type for user-installable processing)

Equipment is more safely fixed with a combination of a stanchion bracket. ◎

It is acceptable for 30mm square aluminum frame.

It is acceptable for 40mm square aluminum frame.

AB3070 30×70×8

AB4075 40×75×10

AB4090 40×90×10

●For 300, 400 type, please match the mark on both edge phase on assembly.

Dimensional drawing (step and measurement by size)

PS(φ6) series