

AG11, AG12

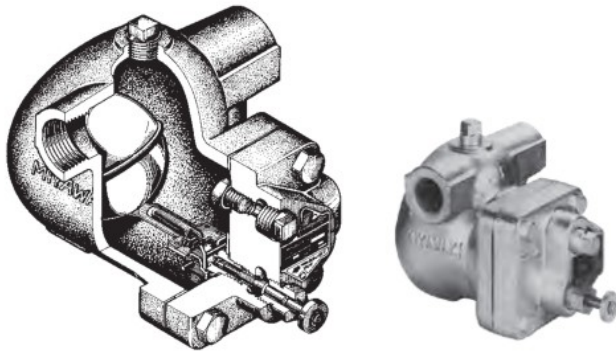

Capacity Chart AG11, AG12

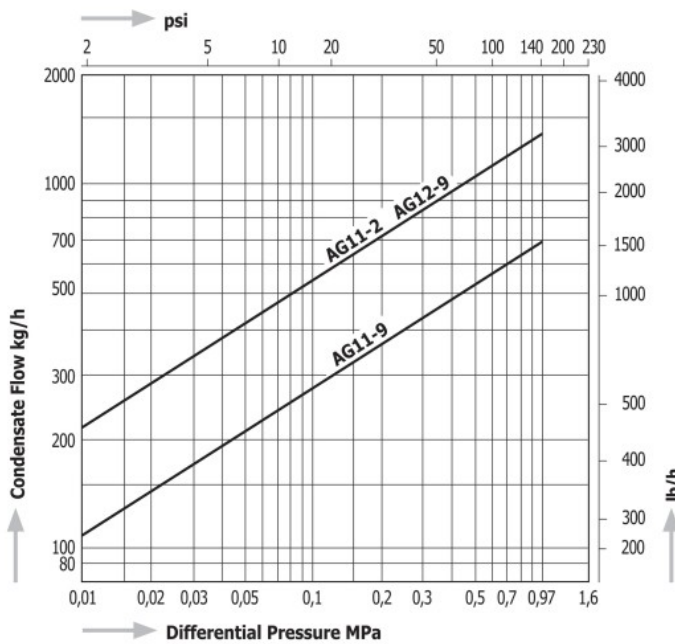

AGC1V

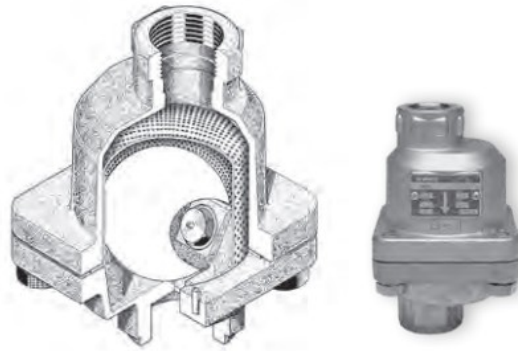

Capacity Chart AGC1V

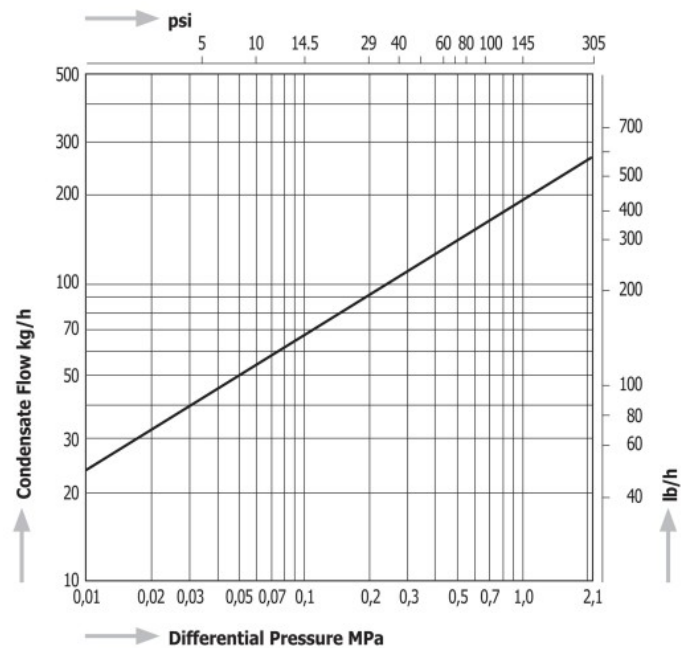

Dimensions AG11, AG12

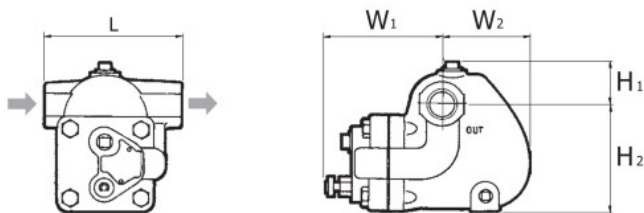

Dimensions

AGC1V, AGC1V-W

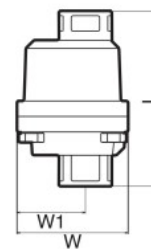

AGC1V-F

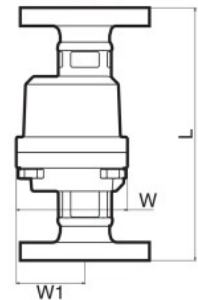

Model	Connections	Size	Max. Operating Pressure		Max. Operating Temperature		Dimensions (mm)					Dimensions (in)					Body Material	Weight			
			MPa	psig	°C	°F	L	H ₁	H ₂	W ₁	W ₂	W	L	H ₁	H ₂	W ₁		W ₂	W	kg	lb
AG11 - 2 AG12 - 9	Screwed Rc, NPT	1/2", 3/4"	0,2	29	100	212	120	37	92	121	60	-	4.7	1.5	3.6	4.8	2.4	-	Cast Iron FC250	3,9	8.6
		3/4", 1"	0,97	140			140	47	113	129	92	-	5.5	1.9	4.4	5.1	3.6	-		5,9	13.0
AGC1V	Screwed Rc, NPT	1/2"	2,1	305	350	662	127	-	-	53	-	86	5.0	-	-	2.1	3.4	Stainless Steel SCS13A	1,8	4.0	
		3/4"					136						5.4			1,9			4.2		
		1"					140						5.5			2,0			4.4		
AGC1V-W	Socket Weld JIS, ASME, DIN	1/2"	2,1	305	350	662	127	-	-	53	-	86	5.0	-	-	2.1	3.4	Stainless Steel SCS13A	1,8	4.0	
		3/4"					136						5.4			1,9			4.2		
		1"					140						5.5			2,0			4.4		
AGC1V-F	Flanged JIS, ASME, DIN	1/2"	2,1	305	350	662	175	-	-	53	86	6.9	-	-	2.1	3.4	Stainless Steel SCS13A	3,3	7.3		
		3/4"					195					7.7			4,5			9.9			
		1"					215					8.5			5,3			11.7			

Horizontal version for AGC1V is available as special design. For more details, please contact MIYAWAKI Inc. or an authorized representative.