

GC1

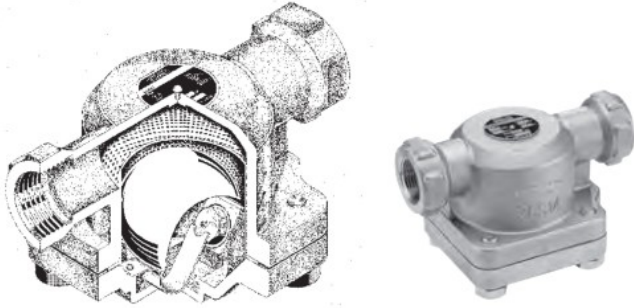

Horizontal installation

GC1V

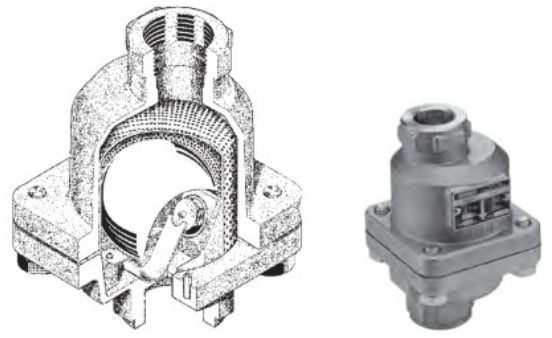

Vertical installation

Dimensions

Screwed, Socket Weld

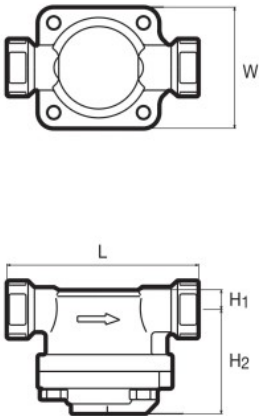

GC1

Flanged

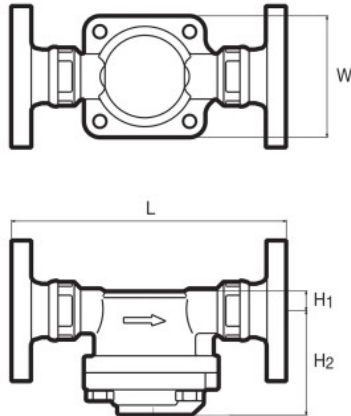

GC1V

Screwed, Socket Weld

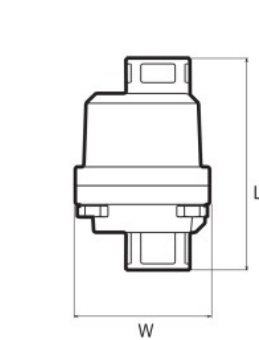

Flanged

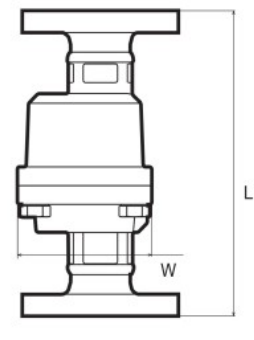

Capacity Chart GC1 / GC1V

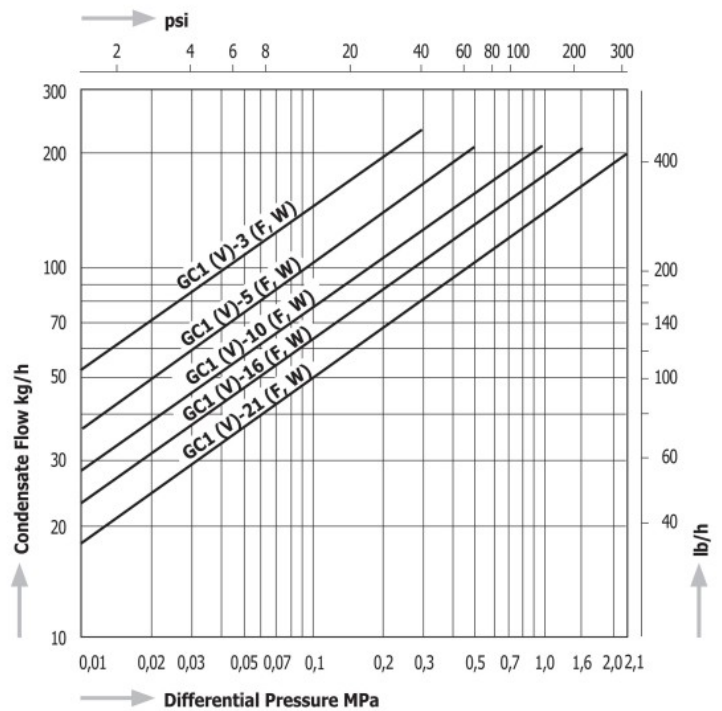

Available pressure ranges GC1/GC1V

Model	Max. Operating Pressure	
	MPa	psig
GC1 / GC1V - 21	2,1	305
GC1 / GC1V - 16	1,6	230
GC1 / GC1V - 10	1,0	145
GC1 / GC1V - 5	0,5	72.5
GC1 / GC1V - 3	0,3	43.5

Model	Connections	Size	Max. Operating Pressure		Max. Operating Temperature		Dimensions (mm)				Dimensions (in)				Body Material	Weight	
			MPa	psig	°C	°F	L	H1	H2	W	L	H1	H2	W		kg	lb
GC1 (GC1V)	Screwed Rc, NPT	1/2"	2,1	305	350	662	127	15	75	86	5.0	0.6	3.0	3.4	Stainless Steel SCS13A	1,8	4.0
		3/4"					136				5.4					1,9	4.2
		1"					140				5.5					2,0	4.4
GC1-W (GC1V-W)	Socket Weld JIS, ASME, DIN	1/2"	2,1	305	350	662	127	15	75	86	5.0	0.6	3.0	3.4	Stainless Steel SCS13A	1,8	4.0
		3/4"					136				5.4					1,9	4.2
		1"					140				5.5					2,0	4.4
GC1-F (GC1V-F)	Flanged JIS, ASME, DIN	1/2"	2,1	305	350	662	175	15	75	86	6.9	0.6	3.0	3.4	Stainless Steel SCS13A	3,3	7.3
		3/4"					195				7.7					4,5	9.9
		1"					215				8.5					5,3	11.7