

Dimensions of JIS 5K flanges

JIS 5K フランジの寸法

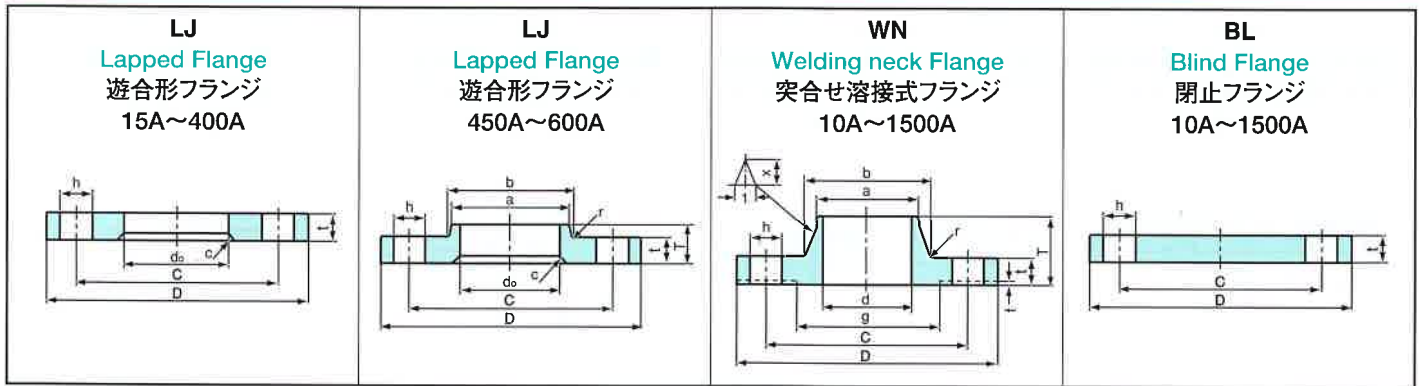

Unit 単位: mm

Nominal Size 呼び径	Thickness of Flange フランジの厚さ		Diam. of Hub at Small End ハブの径小径側		Diam. of Hub at Large End ハブの径大径側		Taper of Hub ハブのテーパ	Length thru. Hub フランジの全長		Chamfering 面取り (1)	Radius of Fillet at Base of Hub すみ肉の半径		Thick-ness フランジ厚さ	Taper of Hub ハブのテーパ
	Except BL 以外	BL	SOH SW LJ, TR	WN	SOH SW LJ, TR	WN		SOH SW LJ, TR	WN		SOH SW LJ, TR	WN		
	A	t	a		b		x	T		c	r		t	x
10	9		23	17.3	26	26	1.25	13	24	—	4	4	—	—
15	9		27	21.7	30	31	1.25	13	25	3	4	4	—	—
20	10		33	27.2	36	38	1.25	15	28	3	4	4	—	—
25	10		41	34.0	44	46	1.25	17	30	3	4	4	—	—
32	12		50	42.7	53	55	1.25	19	33	4	4	4	—	—
40	12		56	48.6	60	62	1.25	20	34	4	4	4	—	—
50	14		69	60.5	73	73	1.25	24	36	4	4	4	—	—
65	14		86	76.3	91	91	1.25	27	39	5	4	4	—	—
80	14		99	89.1	105	105	1.25	30	41	5	4	4	—	—
90	14		—	101.6	—	117	1.25	—	41	5	—	4	—	—
100	16		127	114.3	130	128	1.25	36	41	5	4	4	—	—
125	16		154	139.8	161	156	1.25	40	43	6	4	4	—	—
150	18		182	165.2	189	184	1.25	40	49	6	4	4	—	—
175	18		—	190.7	—	209	1.25	—	49	—	—	4	—	—
200	20		—	216.3	—	235	1.25	—	53	6	—	4	—	—
225	20		—	241.8	—	261	1.25	—	54	—	—	4	—	—
250	22		—	267.4	—	290	1.25	—	61	6	—	4	—	—
300	22		—	318.5	—	342	1.25	—	62	9	—	4	—	—
350	24		—	355.6	—	385	1.25	—	73	9	—	4	—	—
400	24		—	406.4	—	438	1.25	—	76	9	—	4	—	—
450	24		495	457.2	500	491	1.25	40	79	9	5	5	—	—
500	24		546	508.0	552	541	1.25	40	79	9	5	5	—	—
550	26		597	558.8	603	593	1.25	42	81	9	5	5	—	—
600	26		648	609.6	654	643	1.25	44	81	9	5	5	—	—
650	26	28	702	660.4	708	698	1.25	48	85	—	5	5	—	—
700	26	30	751	711.2	758	748	1.5	48	94	—	5	5	36	1.25
750	28	32	802	762.0	810	802	1.5	52	100	—	5	5	38	1.25
800	28	34	854	812.8	862	852	1.5	52	100	—	5	5	38	1.25
850	28	36	904	863.6	912	902	1.75	54	108	—	5	5	38	1.5
900	30	36	956	914.4	964	952	1.75	56	108	—	5	5	40	1.5
1000	32	40	1058	1016.0	1066	1052	2	60	116	—	5	5	50	1.5
1100	32	44	1158	1117.6	1170	1162	2	71	136	—	7	8	56	1.5
1200	34	48	1260	1219.2	1272	1272	2	77	155	—	7	8	62	1.5
1350	34	54	1414	1371.6	1426	1427	2	80	164	—	7	8	62	1.5
1500	36	58	1568	1524.0	1580	1582	2	86	172	—	7	10	66	1.5

Notes:

- (1) The rounding at radius c is acceptable.
- (2) By the agreement of the delivery parties, these sizes can be adopted.

注:

- (1) c の寸法を半径とする丸めでも良い。
- (2) 受け渡し当事者間の協議によって、この寸法としても良い。