



End Brushes with Shank Ø 6 mm, Stainless Steel and Brass Wire

	D	DH	H	GL	RPM	Pack.	Shape				7	
								ROF 0.20 0.008"	ROF 0.30 0.012"	RO4 0.30 0.012"	MES 0.20 0.008"	MES 0.30 0.012"
	mm inch	mm inch	mm inch	mm inch	max.			Art.-No.	Art.-No.	Art.-No.	Art.-No.	Art.-No.
1	12 1/2	10 3/8	20 3/4	60 2 3/8	20,000	10		451.341	451.361	451.461	451.541	451.561
2	12 1/2	10 3/8	20 3/4	60 2 3/8	20,000	10			451.362		451.542	451.562
3	12 1/2	10 3/8	20 3/4	120 4 3/4	15,000	10		458.341	458.361		458.541	458.561
4	17 5/8	16 5/8	22 7/8	65 2 1/2	20,000	10		452.341	452.361		452.541	452.561
	23 7/8	22 7/8	25 1	68 2 3/4	18,000	10		453.341	453.361		453.541	453.561
5	30 1 1/4	29 1 1/8	25 1	68 2 3/4	18,000	10		456.341	456.361		456.541	456.561
6	50 2	22 7/8	18 3/4	68 2 3/4	18,000	10			453.363			

End Brushes with Shank Ø 6 mm, complete Stainless Steel

D	DH	H	GL	RPM	Pack.	Shape	ROF 0.30 0.012"
mm inch	mm inch	mm inch	mm inch	max.			Art.-No.
12 1/2	10 3/8	20 3/4	60 2 3/8	20,000	10		451.305
17 5/8	16 5/8	22 7/8	65 2 1/2	20,000	10		452.304
23 7/8	22 7/8	25 1	68 2 3/4	18,000	10		453.301



Brushes also available with shrink tubing.

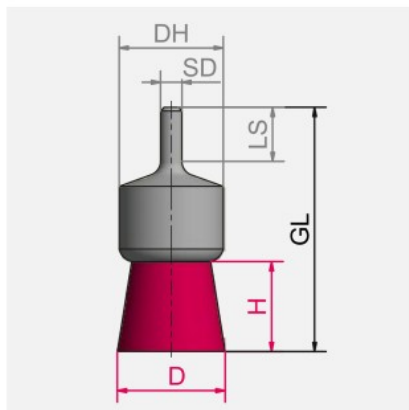

Item Nos. in bold are available ex stock.
Consider our minimum order value for *italic printed* article numbers (see page 178).

- STA = steel wire, crimped
- STH = steel wire, high tensile, crimped
- STM = brass coated steel, crimped
- STL = cord wire, crimped
- ROF = stainless steel wire, crimped
- MES = brass wire, crimped