

平歯車 SPUR GEARS

モジュール **0.75** 圧力角 20° (並歯)
MODULE 20° PRESSURE ANGLE FULL DEPTH TOOTH

JIS B 1702-1 (ISO) 8~9 級
System of accuracy : JIS B 1702-1(ISO) class 8-9

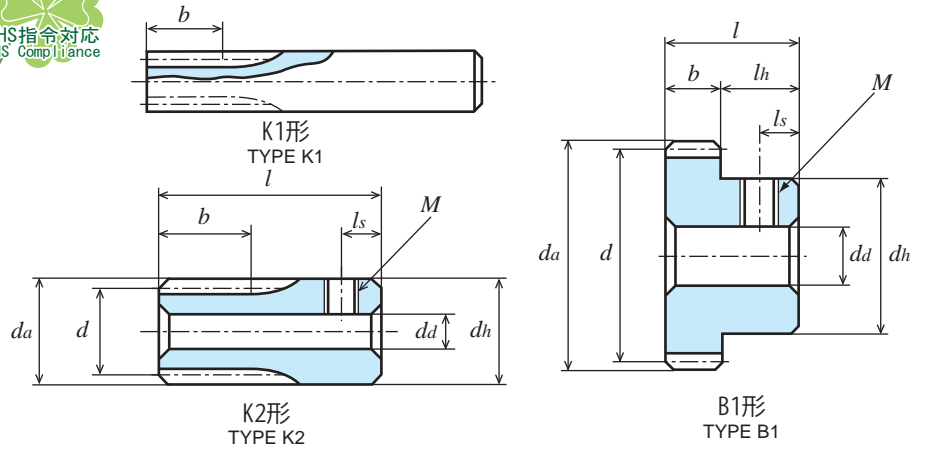

S45C 機械構造用炭素鋼 (JIS G 4051) Material : Carbon Steel (ISO C45)

単位 : mm
Dimensions : mm

商品記号 Catalogue Number	歯数 Number of Teeth <i>z</i>	基準円直径 Reference Diameter <i>d</i>	歯先円直径 Tip Diameter <i>da</i>	形 Type	歯幅 Face Width <i>b</i>	穴径 Bore Diameter <i>da</i> (H7)	ハブ外径 Hub Diameter <i>dh</i>	ハブ長さ Hub Projection <i>lh</i>	全長 Overall Length <i>l</i>	ねじ Set Screw		重量 Weight <i>W</i> (g)
										<i>M</i>	<i>ls</i>	
S75S 10K - 0809	10	φ 7.5	φ 9	K1	8	-	φ 9	47	55	-	-	26.3
S75S 12K - 0811	12	φ 9	φ 10.5	K1	8	-	φ 11	47	55	-	-	39.1
S75S 14K + 0805	14	φ 10.5	φ 12	K2	8	φ 5	φ 12	12	20	M3	3	12.9
S75S 15K + 0805	15	φ 11.25	φ 12.75	K2	8	φ 5	φ 12.75	12	20	M3	3	15.0
S75S 16B + 0805	16	φ 12	φ 13.5	B1	8	φ 5	φ 10	7	15	M4	3.5	8.9
S75S 18B + 0805	18	φ 13.5	φ 15	B1	8	φ 5	φ 11	7	15	M4	3.5	11.7
S75S 20B + 0806	20	φ 15	φ 16.5	B1	8	φ 6	φ 12	7	15	M4	3.5	13.8
S75S 24B + 0806	24	φ 18	φ 19.5	B1	8	φ 6	φ 14	7	15	M4	3.5	20.8
S75S 25B + 0806	25	φ 18.75	φ 20.25	B1	8	φ 6	φ 14	7	15	M4	3.5	22.2
S75S 28B + 0806	28	φ 21	φ 22.5	B1	8	φ 6	φ 14	7	15	M4	3.5	26.6
S75S 30B + 0806	30	φ 22.5	φ 24	B1	8	φ 6	φ 15	7	15	M4	3.5	31.0
S75S 32B + 0606	32	φ 24	φ 25.5	B1	6	φ 6	φ 15	9	15	M4	4	30.1
S75S 35B + 0606	35	φ 26.25	φ 27.75	B1	6	φ 6	φ 18	9	15	M4	4	39.7
S75S 36B + 0606	36	φ 27	φ 28.5	B1	6	φ 6	φ 18	9	15	M4	4	41.2

【+】にはセットスクリューは付いております。
【+】: Gear with threaded hole / with set screw.

許容伝達動力表 曲げ強さ (W)

Allowable transfer capability table (W) Bending Strength

商品記号 Catalogue Numbers	回転速度 (min ⁻¹) revolution/min						
	10	100	200	400	800	1,200	1,500
S75S 10K - 0809	1.10	11.07	22.14	44.29	88.59	132.88	166.10
S75S 12K - 0811	1.53	15.28	30.56	61.12	122.24	183.36	229.20
S75S 14K + 0805	1.99	19.92	39.84	79.67	159.35	239.02	298.77
S75S 15K + 0805	2.23	22.32	44.64	89.29	178.58	267.86	334.83
S75S 16B + 0805	2.48	24.77	49.54	99.09	198.18	297.27	371.59
S75S 18B + 0805	2.98	29.78	59.56	119.12	238.23	357.35	442.68
S75S 20B + 0806	3.50	34.97	69.93	139.86	279.72	419.58	510.83
S75S 24B + 0806	4.56	45.58	91.17	182.33	364.66	536.45	643.79
S75S 25B + 0806	4.83	48.30	96.59	193.18	386.36	564.46	676.47
S75S 28B + 0806	5.65	56.54	113.08	226.16	452.32	647.45	772.83
S75S 30B + 0806	6.21	62.08	124.17	248.66	496.66	701.46	835.14
S75S 32B + 0606	5.08	50.78	101.55	203.10	405.88	566.16	672.37
S75S 35B + 0606	5.72	57.16	114.32	228.63	450.54	625.02	739.59
S75S 36B + 0606	5.93	59.30	118.60	237.20	465.26	644.30	761.51

The above numerical values are equivalent to JGMA formulas as reference only.
動力の換算式は P26 をご参照ください。
Please refer to the conversion formulas of power on page P26.

RoHS 対応

2006年11月生産開始分より欧州 RoHS 指令に対応できる商品を提供しています。
We supplied the KG-products with RoHS compliance of EU to all our valued customers since November 2006