

# Triple Speed/Carrier Chains

## ● Order No. Example

**C4AFT**

Aluminum Frame No.

◇ Aluminum Frame for use with Triple Speed/Carrier Chain  
(For use with plastic rollers)

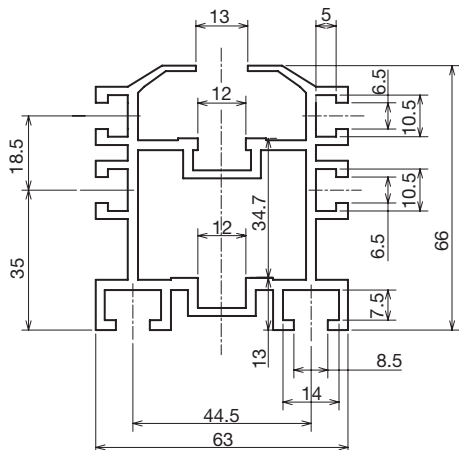

CZ4/CY4 Dedicated Aluminum Frame

Aluminum Frame No.	Length/Unit	Material	¥
<b>C4AFT</b>	3m	 A6063S T5	

◇ Aluminum Frame with steel rail for use with Triple Speed/Carrier Chain  
(For use with steel rollers and plastic rollers)

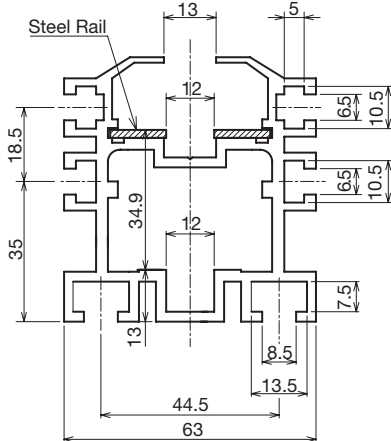

CZ4/CY4 Dedicated Aluminum Frame

Aluminum Frame No.	Length/Unit	Material	¥
<b>CZ4AFS</b>	4m	 A6063S T5	

⚠ Steel rails, end plates, and cylindrical rollers are included.

◇ Aluminum Side Frame for use with Triple Speed/Carrier Chain  
(Pallet Guide Rail)

Compatible Aluminum Frames: C4AF/CZ4AFS

Side Frame No.	Length/Unit	Material	¥
<b>C4AFSD</b>	3m	 A6063S T5	

