

Plastic Idler Sprockets

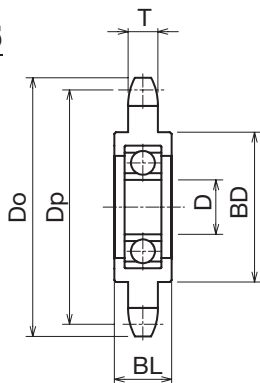

Order No. Example

EPID 40C 15 D15

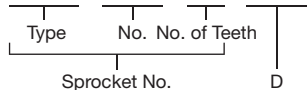

Universal plastic/polyamide resin 6 nylon is used for this idler sprocket to reduce weight and noise.
Operating temperature: -10 to +80°C

6 nylon

Type	No.	No. of Teeth	Inner Diameter D	Outer Diameter Do	Pitch Diameter Dp	Tooth Width T	Boss BD	Total Width BL	Used Bearing	Weight kg	Idler Pin Applicable Size	ID Adapter Applicable Size	¥
EPID	35C	18	15	60	54.85	4.3	42	17	6202ZZ	0.07	IDP6202S	AD6202	
	40C	15	15	67	61.08	7.2	42	17	6202ZZ	0.07	IDP6202S	AD6202	
	50C	13	15	74	66.34	8.7	42	17	6202ZZ	0.08	IDP6202S	AD6202	
	60C	11	15	76	67.62	11.7	42	17	6202ZZ	0.09	IDP6202S	AD6202	



Order Method

Sprocket No. and Quantity



Precautions

* The bearing is located in the center of the sprocket.



Postage

Same-day shipping



Guide

* Since we also manufacture sizes other than those in the catalog upon request, please contact our company's sales office for details.



Use Examples

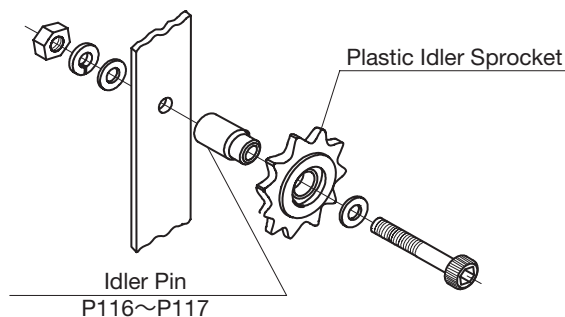

* Use the ID adapter.

P114

