

# CKR-20AS/25AS/32AS/40AS/50AS/63AS

## 外形図

CADデータ有り。お申し込みは ▶518P

### ■CKR-20AS (最適把持力 60N~100N)

#### CKR-20AS 標準

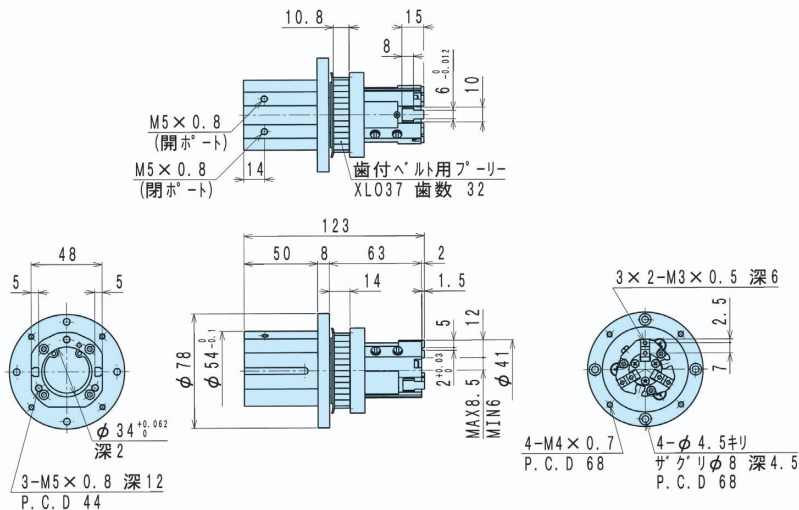

### ■CKR-25AS (最適把持力 80N~180N)

#### CKR-25AS 標準

