

## 外形図

### ■CKS-08AS (最適把持力 30N~60N)

#### CKS-08AS 標準

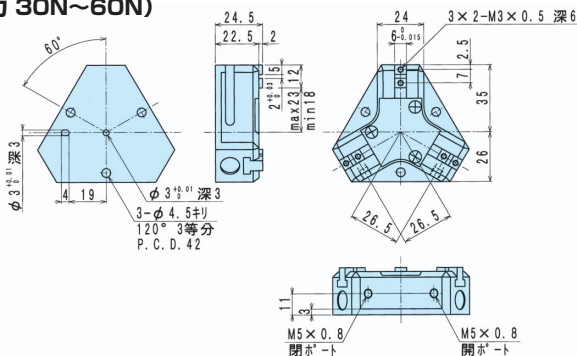

#### CKS-08AS-W

(スプリングカ (3本) 2.1~4.8N)

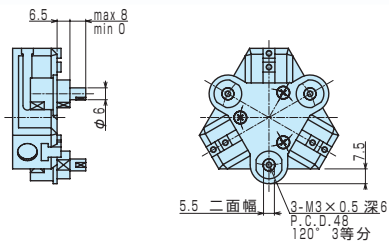

### ■CKS-12AS (最適把持力 50N~130N)

#### CKS-12AS 標準

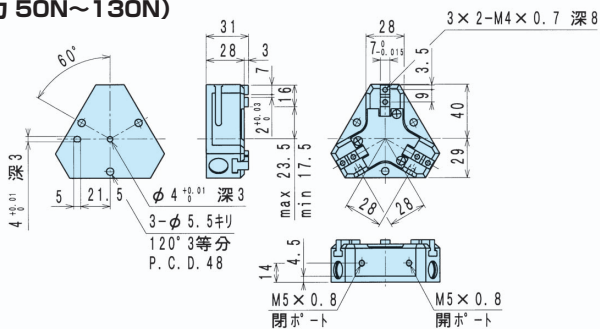

#### CKS-12AS-W

(スプリングカ (3本) 4.5~11.4N)

