

## Model MPV-MF FLEXIBLE HOLDER

ELECTROMAGNETIC CHUCKS  
ELECTROMAGNETIC CHUCK CONTROLLERS  
PERMANENT MAGNETIC CHUCKS  
PERMANENT ELECTROMAGNETIC CHUCKS



MPV-MF30

### Universal use! Convenient multi clammer !!

Patent pending

#### Parts for sale !

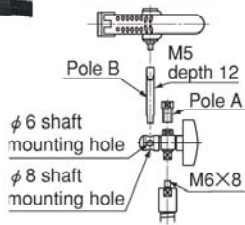

#### An example of mounting

#### [Application]

Suitable for auxiliary clamping of parts or tools during machining or assembling work.

#### [Features]

- Due to various connection options for holding metal parts, application in various use is excellent. In addition to main clammer, shaft of dia. 6, dia. 8 can be fixed.
- Top flexible edge : M6 male screw, top pole edge: M5 male screw parts can be changed.
- Magnetic base with on/off switch makes setting and removing easily done.

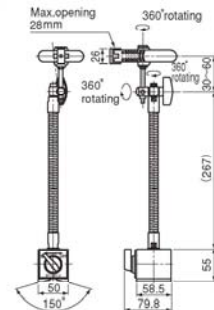

Model	Holding Power	Allowable holding weight	Mass
MPV-MF30	784N (80kgf)	0.6kg	1.4kg/3.08 lb

※Clamper with Pole B is sold separately.  
※Clamper can clamp a work piece which length is shorter than 28mm.

## Model MPV-CL FLEXIBLE CLAMP

BLOCKS FOR MC  
VACUUM CHUCKS  
PROMELTA SYSTEM



MPV-CL30

#### Parts for sale !

#### [Application]

Suitable for soldering of circuit board of electric parts.  
Suitable for holding parts during assembly.  
Suitable for wiring as it can clamp electric cables.

#### [Features]

- The employment of a powerful ON/OFF selectable magnet holder facilitates installation on iron-made worktables and worktables of machine tools.
- The clamp parts are equipped with tough plastic clammers and can be tilted freely.
- The clammers open 28 mm maximum and can be moved up and down in a range of about 90 mm. The clammers are exchangeable. (Optional)

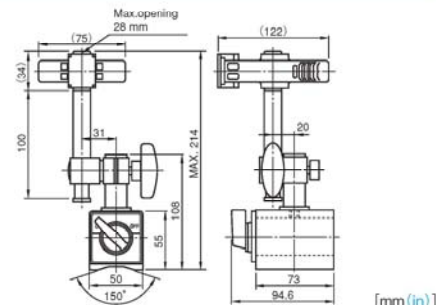

Model	Holding Power	Mass
MPV-CL30	1000N (100kgf)	2.7kg/6.0 lb

※The holding power applies to SS400, thickness 10 mm and ground surface.

## Model MPV-F FLEXIBLE VICE

SINE BAR CHUCKS  
MAGNETIC BLOCKS  
WORKING TOOLS



MPV-F50A

#### Parts for sale !

#### [Application]

Suitable for temporarily holding workpieces during assembly.  
Suitable for such jobs as manual filing and drilling and tapping of nonmagnetic materials.

#### [Features]

- The employment of a powerful ON/OFF selectable magnet holder facilitates installation on iron-made worktables and worktables of machine tools.
- The vice can be tilted freely to secure workpieces according to their shapes and machining directions.
- The plates on the workpiece clamping parts are made of nylon to hold non-flat workpieces strongly. The plates are exchangeable. (Optional)

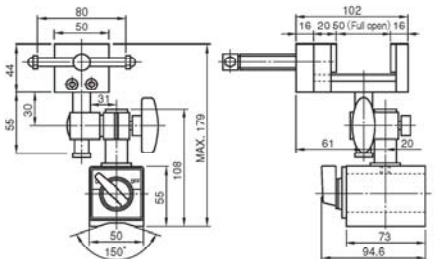

Model	Holding Power	Mass
MPV-F50A	78N (80kgf)	2.7kg/6.0 lb

※The holding power applies to SS400, thickness 10 mm and ground surface.

## Model MPV MAGVICE\*

MEASURING TOOL HOLDERS  
MAGNETIC HOLDERS  
MAGNETIC TOOLS



#### [Application]

Suitable for securing irregular shaped workpieces or tapered workpieces and for machining end faces of round bars and flat workpieces.

#### [Features]

- The force to secure a workpiece is produced by a magnetic force. Thus, unlike mechanical clamping, no undue force is applied. (Nonmagnetic workpieces cannot be held.)
- The select handle can be operated from both sides.
- Can be mounted on a magnetic chuck on a machine.

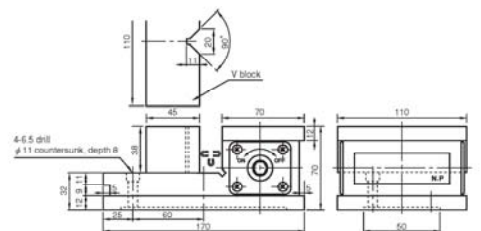

- Magnetic force: Side slip resistance is 575 N (57.5 kg) for iron square bars of 30 mm × 30 mm × 130 mm and 480 N (48 kgf) for iron round bars of  $\phi 30$  × 130 mm thanks to the strong built-in permanent magnet. Thus, the MAGVICE works well in grinding operations also.
- Mass: 7.3 kg