

PTBM

サービステー

Male run tee

樹脂製

Plastic body

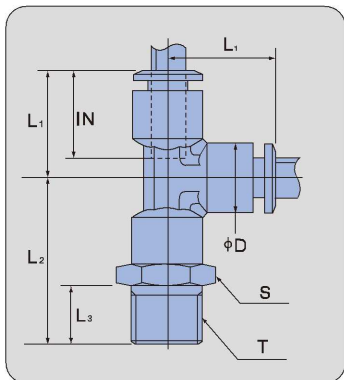

部品番号 PART NO.	適用チューブ 外径 TUBE O.D. TO BE USED (mm)	T (R·M)	φD (mm)	S 六角 対辺 HEX (mm)	L ₁ (mm)	L ₂ (mm)	L ₃ (mm)	IN (mm)	重量 WEIGHT (g)	最小内径 ORIFICE (mm)	有効断面積 EFFECTIVE SECTIONAL AREA (mm ²)	
											ナイロンチューブ NYLON TUBE	ウレタンチューブ POLYURETHANE TUBE
PTBM- 4-M5-PM	4	M5	10.5	12	17	23	5	13	10	2.5	2.6	2.6
PTBM- 4-PT1/8-PM	4	1/8	10.5	12	17	26	8	13	13	3	2.9	2.9
PTBM- 4-PT1/4-PM	4	1/4	10.5	14	17	29	11	13	16	3	2.9	2.9
PTBM- 6-M5-PM	6	M5	12.5	12	18	24	5	14	12	2.5	3.4	3.4
PTBM- 6-PT1/8-PM	6	1/8	12.5	12	18	27	8	14	15	4	6.8	6.8
PTBM- 6-PT1/4-PM	6	1/4	12.5	14	18	30	11	14	19	4	6.8	6.8
PTBM- 6-PT3/8-PM	6	3/8	12.5	17	18	31	12	14	29	4	6.8	6.8
PTBM- 8-PT1/8-PM	8	1/8	14.5	17	19	28	8	15	17	6	20.3	11.6
PTBM- 8-PT1/4-PM	8	1/4	14.5	17	19	31	11	15	24	6	20.3	11.6
PTBM- 8-PT3/8-PM	8	3/8	14.5	17	19	32	12	15	28	6	20.3	11.6
PTBM-10-PT1/8-PM	10	1/8	19	19	25	34	9	19	35	6	23.5	14.5
PTBM-10-PT1/4-PM	10	1/4	19	19	25	37	12	19	36	8	27.0	20.5
PTBM-10-PT3/8-PM	10	3/8	19	19	25	37	12	19	44	8	36.0	24.0
PTBM-10-PT1/2-PM	10	1/2	19	22	25	41	16	19	73	8	36.0	24.0
PTBM-12-PT1/8-PM	12	1/8	22	22	29	37	9	21	43	6	28.0	19.3
PTBM-12-PT1/4-PM	12	1/4	22	22	29	41	12	21	52	8	45.0	36.0
PTBM-12-PT3/8-PM	12	3/8	22	22	29	41	12	21	62	10	51.0	42.2
PTBM-12-PT1/2-PM	12	1/2	22	22	29	44	16	21	77	10	55.0	42.2

※R (PT) ネジには、ネジサイズが一目で判別できるR (PT) ネジ別の色シールがついています。PAT.NO.1820889
The R (PT) screws have different color seals so that they can be distinguished at a glance.
●R1/8: 白 white ●R1/4: 青 blue ●R3/8: 黄 yellow ●R1/2: 灰 gray