

Rubber Wheel Type:  
Rigid Caster

# G-WK

Rubber Wheel Type:  
Wheel Only

# G-W

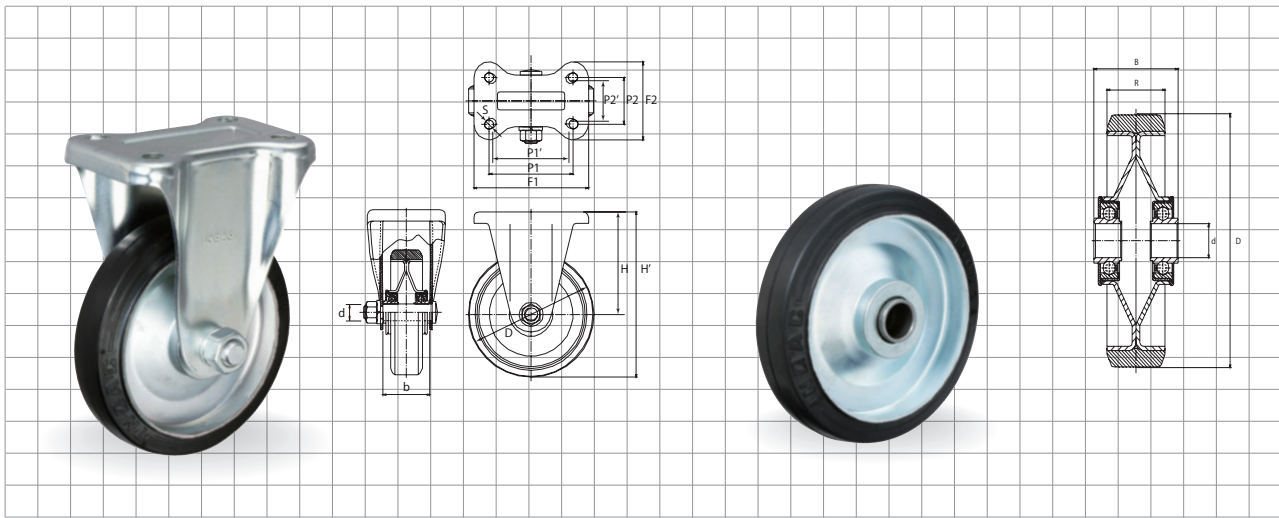

| Product Name   | Wheel diameter | Mounting Height | Bracket Height | Top plate | Hole pitch         | Hole diameter | Fork width | Shaft  | Maximum load |     | Quantity per case |
|----------------|----------------|-----------------|----------------|-----------|--------------------|---------------|------------|--------|--------------|-----|-------------------|
|                | D              | H'              | H              | F1/F2     | P1/P2 (P1'/P2')    | S             | b          | d      | N            | kg  | Qty               |
| <b>G-75WK</b>  | <b>75</b>      | 100             | 63             | 95/72     | 63/40              | 9.5           | 36         | 10/M8  | 784          | 80  | 40                |
| <b>G-100WK</b> | <b>100</b>     | 144             | 94             | 115/80    | 80/45<br>(75/40)   | 10.5          | 43         | 12/M10 | 1176         | 120 | 20                |
| <b>G-130WK</b> | <b>130</b>     | 177             | 112            | 137/93    | 100/56<br>(95/93)  | 11.5          | 52         | 20/M16 | 1764         | 180 | 10                |
| <b>G-150WK</b> | <b>150</b>     | 198             | 123            | 137/93    | 100/56<br>(95/93)  | 11.5          | 56         | 20/M16 | 1960         | 200 | 10                |
| <b>G-180WK</b> | <b>180</b>     | 240             | 150            | 151/102   | 112/63<br>(107/60) | 11.5          | 56         | 20/M16 | 2303         | 235 | 5                 |
| <b>G-200WK</b> | <b>200</b>     | 250             | 150            | 151/102   | 112/63<br>(107/60) | 11.5          | 56         | 20/M16 | 2450         | 250 | 5                 |
| <b>G-250WK</b> | <b>250</b>     | 305             | 180            | 200/140   | 140/80             | 14            | 90         | 25/M16 | 3332         | 340 | 2                 |
| <b>G-300WK</b> | <b>300</b>     | 374             | 224            | 220/150   | 160/90             | 14            | 100        | 25/M16 | 3528         | 360 | 2                 |

| Product Name   | Wheel diameter | Bearing | Tire width | Boss width | Shaft | Maximum load |     | Quantity per case |
|----------------|----------------|---------|------------|------------|-------|--------------|-----|-------------------|
|                | D              |         | R          | B          | d     | N            | kg  | Qty               |
| <b>G-75W</b>   | <b>75</b>      | 1030    | 30         | 35         | 10    | 784          | 80  | 80                |
| <b>G-100W</b>  | <b>100</b>     | 1232    | 32         | 42         | 12    | 1176         | 120 | 50                |
| <b>G-125W</b>  | <b>125</b>     | 2042    | 36         | 52         | 20    | 1764         | 180 | 25                |
| <b>G-130W</b>  | <b>130</b>     | 2042    | 36         | 52         | 20    | 1764         | 180 | 25                |
| <b>G-150W</b>  | <b>150</b>     | 2042    | 38         | 55         | 20    | 1960         | 200 | 20                |
| <b>G-180W</b>  | <b>180</b>     | 2042    | 40         | 55         | 20    | 2303         | 235 | 10                |
| <b>G-200W</b>  | <b>200</b>     | 2042    | 42         | 55         | 20    | 2450         | 250 | 10                |
| <b>G-250W</b>  | <b>250</b>     | 2552    | 50         | 64         | 25    | 3332         | 340 | 5                 |
| <b>G-300W</b>  | <b>300</b>     | 2552    | 50         | 71         | 25    | 3528         | 360 | 5                 |
| <b>GB-75W</b>  | <b>75</b>      | Bush    | 30         | 35         | 10    | 784          | 80  | 80                |
| <b>GB-100W</b> | <b>100</b>     | Bush    | 32         | 42         | 12    | 1176         | 120 | 50                |
| <b>GB-130W</b> | <b>130</b>     | Bush    | 36         | 52         | 20    | 1764         | 180 | 25                |
| <b>GB-150W</b> | <b>150</b>     | Bush    | 38         | 55         | 20    | 1960         | 200 | 20                |
| <b>GB-180W</b> | <b>180</b>     | Bush    | 40         | 55         | 20    | 2303         | 235 | 10                |
| <b>GB-200W</b> | <b>200</b>     | Bush    | 42         | 55         | 20    | 2450         | 250 | 10                |

For Safe Use

Casters for Middle-Size Loads

Low Starting Resistance Casters

Caster for Tow Trolleys