

# AMWF-L-S

# PNEUMATIC FLEX LOCATOR PINS



**AMWF-L-S**



**AMWF-L-S-G**

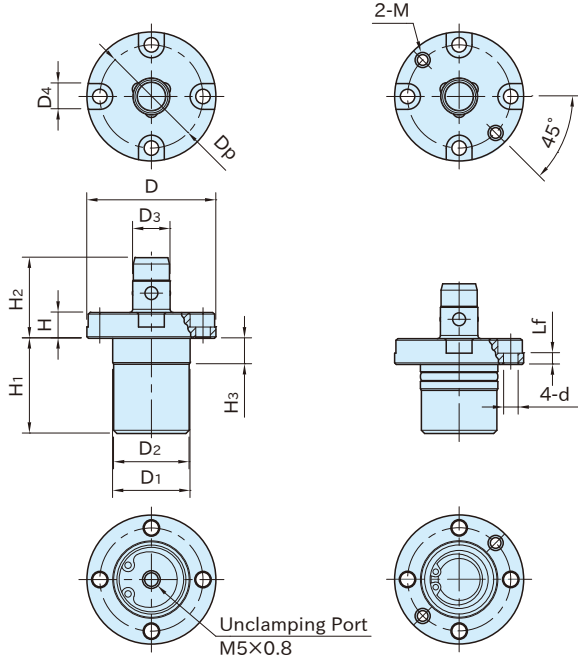

**AMWF-L-S** (Port Style)

**AMWF-L-S-G** (Direct Style)

Body	Ball	Coiled Spring
S45C steel Electroless nickel plated	SUS440C stainless steel	SUS304WPB stainless steel

Part Number	D <sub>1</sub> (g6)	H <sub>3</sub>	D <sub>2</sub>	H <sub>1</sub>	D	H	D <sub>3</sub> (h8)	H <sub>2</sub>	d	L <sub>f</sub>	D <sub>4</sub>	D <sub>p</sub>
<b>AMWF18L-4S</b>	24	8	23.4	29.5	40	8	12	25	4.5	3.5	8	32
<b>AMWF26L-4S</b>	32	8.5	31.4	31.7	51	9.5	16	28.5	5.5	4	9.5	41
<b>AMWF18L-4S-G</b>	24	8	23.4	24.5	40	8	12	25	4.5	3.5	8	32
<b>AMWF26L-4S-G</b>	32	8.5	31.4	25.5	51	9.5	16	28.5	5.5	4	9.5	41

Part Number	M	Air Pressure (MPa)	Clamping Force (N)	Weight (g)
<b>AMWF18L-4S</b>	-	0.5	250	154
<b>AMWF26L-4S</b>	-		350	289
<b>AMWF18L-4S-G</b>	M4×0.7		250	136
<b>AMWF26L-4S-G</b>	M5×0.8		350	252

## Reference

· How To Install PNEUMATIC FLEX LOCATORS

· How To Use PNEUMATIC FLEX LOCATORS