

MBCS

CAM SCREWS

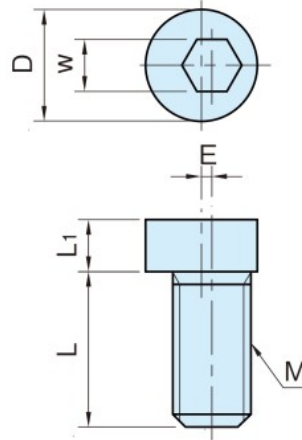

MBCS 04,16 **MBCS** 06~10 **MBCS** 12



| Body |
|---|
| SCM440 steel Quenched & tempered Black oxide finished HRC38~45 |

| Part Number | M | L | L ₁ | D | w | E | Weight (g) |
|---------------|----------|----|----------------|------|----|------|------------|
| MBCS04 | M 4×0.7 | 10 | 3 | 5.5 | 3 | 0.38 | 1 |
| MBCS06 | M 6×1 | 12 | 4 | 8.0 | 4 | 0.5 | 3 |
| MBCS08 | M 8×1.25 | 16 | 5 | 10.3 | 5 | | 8 |
| MBCS10 | M10×1.5 | 20 | 6 | 12.5 | 7 | 0.63 | 14 |
| MBCS12 | M12×1.75 | 25 | 7 | 16.6 | 8 | 1.0 | 25 |
| MBCS16 | M16×2 | 30 | 9 | 20.5 | 12 | 1.27 | 55 |

| Part Number | Proper Clamps | | | |
|---------------|---------------|---------|-------|----------------|
| | MBFC | MBRFC | MBSPC | MBFCS |
| MBCS04 | MBFC04 | - | - | - |
| MBCS06 | MBFC06 | - | - | MBFCS06 |
| MBCS08 | MBFC08 | - | - | - |
| MBCS10 | MBFC10 | MBRFC10 | - | MBFCS10 |
| MBCS12 | MBFC12 | MBRFC12 | MBSPC | MBFCS12 |
| MBCS16 | MBFC16 | MBRFC16 | - | MBFCS16 |

Feature:

Use for a replacement part of the following items.

MBFC **MBRFC** **MBSPC** **MBFCS**

How To Use

