

## マルチマスター

MM...T04/T05/T06/T08/T10/T12

マルチマスター加工ヘッド (ヘッド径5-20mm)

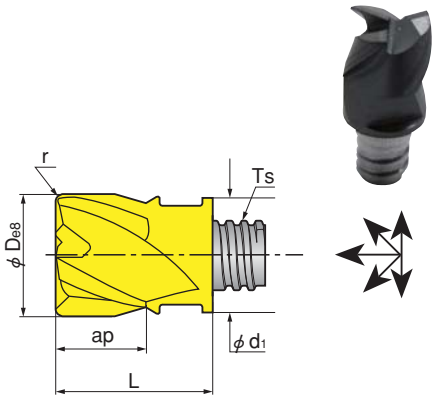

### MM EC... 3枚刃 ねじれ角45°

販売単位：2個

型番	刃列	ねじれ角	寸法 (mm)					PVDコーティング	
			φD	ap	L	r	Ts	φd <sub>1</sub>	IC908
MM EC080B05R000-3T05	3	45°	8	5	10.0	0.0	T05	7.7	●
MM EC100B07R000-3T06	3	45°	10	7	13.0	0.0	T06	9.6	●
MM EC100B12R000-3T06	3	45°	10	12	19.0	0.0	T06	9.6	●
MM EC120B09R000-3T08	3	45°	12	9	16.5	0.0	T08	11.7	●
MM EC120B09R000-3T08 <sup>(1)</sup>	3	45°	12	9	16.5	0.0	T08	11.7	▲

(1) 各刃列にクーラント穴付

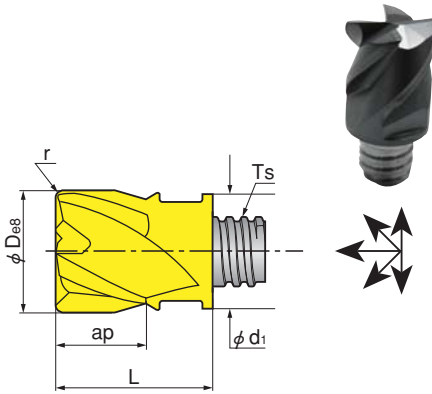

### MM EC... 4枚刃 ねじれ角30°/45°

販売単位：2個

型番	刃列	ねじれ角	寸法 (mm)					PVDコーティング	
			φD	ap	L	r	Ts	φd <sub>1</sub>	IC908
MM EC050B07R000-4T05	4	45°	5	7	15.0	0.0	T05	8.0	●
MM EC060B05R000-4T05	4	45°	6	5	10.0	0.0	T05	8.0	●
MM EC060B04R0.5-4T04	4	45°	6	4	8.5	0.5	T04	5.8	▲
MM EC080B05R000-4T05	4	45°	8	5	10.0	0.0	T05	7.7	●
MM EC080B09R000-4T05	4	45°	8	9	15.0	0.0	T05	7.7	●
MM EC080A05R0.5-4T05	4	30°	8	5	10.0	0.5	T05	7.7	●
MM EC080A09R0.5-4T05	4	30°	8	9	15.0	0.5	T05	7.7	●
MM EC080B05R0.5-4T05	4	45°	8	5	10.0	0.5	T05	7.7	○
MM EC080A05R1.0-4T05	4	30°	8	5	10.0	1.0	T05	7.7	●
MM EC080B05R1.0-4T05	4	45°	8	5	10.0	1.0	T05	7.7	○
MM EC080A05R1.5-4T05	4	30°	8	5	10.0	1.5	T05	7.7	●
MM EC080B05R1.5-4T05	4	45°	8	5	10.0	1.5	T05	7.7	○
MM EC100B07R000-4T06	4	45°	10	7	13.0	0.0	T06	9.6	●
MM EC100A07R0.5-4T06	4	30°	10	7	13.0	0.5	T06	9.6	●
MM EC100B07R0.5-4T06	4	45°	10	7	13.0	0.5	T06	9.6	●
MM EC100A07R1.0-4T06	4	30°	10	7	13.0	1.0	T06	9.6	●
MM EC100B07R1.0-4T06	4	45°	10	7	13.0	1.0	T06	9.6	●
MM EC100B12R000-4T06	4	45°	10	12	19.0	0.0	T06	9.6	●
MM EC120B09R000-4T08	4	45°	12	9	16.5	0.0	T08	11.7	●
MM EC120B14R000-4T08	4	45°	12	14	23.0	0.0	T08	11.7	●
MM EC120A09R0.5-4T08	4	30°	12	9	16.5	0.5	T08	11.7	●
MM EC120B09R0.5-4T08	4	45°	12	9	16.5	0.5	T08	11.7	●
MM EC120A09R1.0-4T08	4	30°	12	9	16.5	1.0	T08	11.7	●
MM EC120B09R1.0-4T08	4	45°	12	9	16.5	1.0	T08	11.7	●
MM EC160B12R000-4T10	4	45°	16	12	20.5	0.0	T10	15.3	●
MM EC160A12R0.5-4T10	4	30°	16	12	20.5	0.5	T10	15.3	●
MM EC160B12R0.5-4T10	4	45°	16	12	20.5	0.5	T10	15.3	●
MM EC160A12R1.0-4T10	4	30°	16	12	20.5	1.0	T10	15.3	●
MM EC160B12R1.0-4T10	4	45°	16	12	20.5	1.0	T10	15.3	●
MM EC160A12R1.5-4T10	4	30°	16	12	20.5	1.5	T10	15.3	●
MM EC160B12R1.5-4T10	4	45°	16	12	20.5	1.5	T10	15.3	●
MM EC160A12R2.0-4T10	4	30°	16	12	20.5	2.0	T10	15.3	●
MM EC160B12R2.0-4T10	4	45°	16	12	20.5	2.0	T10	15.3	●
MM EC160A12R3.0-4T10	4	30°	16	12	20.5	3.0	T10	15.3	●
MM EC160B12R3.0-4T10	4	45°	16	12	20.5	3.0	T10	15.3	●
MM EC160A12R4.0-4T10	4	30°	16	12	20.5	4.0	T10	15.3	●
MM EC160B12R4.0-4T10	4	45°	16	12	20.5	4.0	T10	15.3	●
MM EC200B15R000-4T12	4	45°	20	15	25.5	0.0	T12	18.3	●
MM EC200A15R0.5-4T12	4	30°	20	15	25.5	0.5	T12	18.3	●
MM EC200A15R1.0-4T12	4	30°	20	15	25.5	1.0	T12	18.3	●
MM EC200A15R2.0-4T12	4	30°	20	15	25.5	2.0	T12	18.3	●
MM EC200A15R3.0-4T12	4	30°	20	15	25.5	3.0	T12	18.3	●

ねじサイズ	キーレンチ*	締め付けトルク (N. cm)	在庫	ねじサイズ	キーレンチ*	締め付けトルク (N. cm)	在庫
T04	MM KEY 6×4	400	●	T10	MM KEY 13×8	2800	●
T05		700	●	T12			MM KEY 16×9
T06	MM KEY 8×5	1000	●	T15	MM KEY 20	4000	●
T08	MM KEY 10×7	1500	●				

\* シャンクには付属致しません。別途ご注文下さい。