

15MPa B型銅管くい込継手 (150kgf/cm²)

GT-1型 UNION TEE

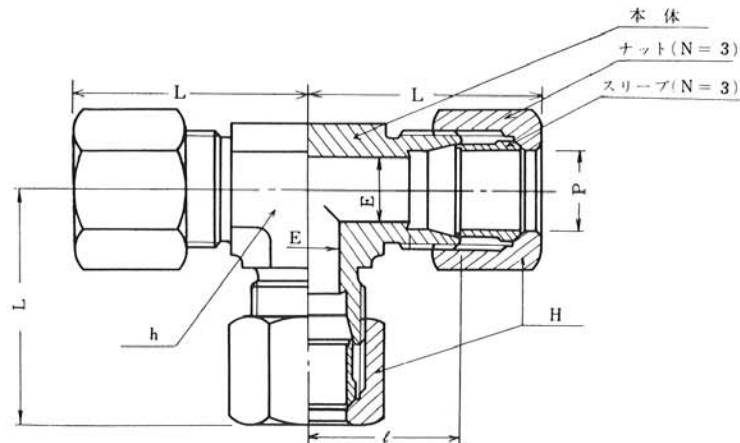

(注) L寸法はナットを締付け前の概略寸法を示す。
L denotes the rough dimensions before tightening the nuts. 単位: mm

各部の記号 Symbols of respective parts 継手の呼称 Designation of joints	適用する管の外径 Tube (O.D) P	Minimum Opening E	二面巾 Width Across Flats h	六角対辺 Opposite sides of hexagon H	ℓ	(約) Approx. L	1組分 Wt weight per set (kg)
GT-1 4-B	4	2.5	12	12	15	23	0.044
GT-1 6-B	6	4	14	14	20	29.5	0.073
GT-1 8-B	8	6	17	17	22	31.5	0.117
GT-1 10-B	10	8	17	19	23	34	0.122
GT-1 12-B	12	10	19	21	24	35	0.163
GT-1 14-B	14	11	23	26	29	41.5	0.248
GT-1 15-B	15	12	23	26	29	41.5	0.252
GT-1 16-B	16	13	23	29	29	41.5	0.343
GT-1 18-B	18	15	29	32	33	45	0.490
GT-1 20-B	20	17	29	35	33	45	0.562
GT-1 22-B	22	18	29	36	34	47.5	0.531
GT-1 25-B	25	20	35	41	36	49.5	0.650
GT-1 28-B	28	22	41	41	40	53	0.887
GT-1 30-B	30	25	41	46	40	53	1.014
GT-1 32-B	32	26	41	50	40.5	53.5	1.165